

## Product End of Life Notification

Date: December 22<sup>nd</sup>, 2011

### Product Being Discontinued

Model Number	Description
232CL2	CURRENT LOOP CONV

### Replacement Product

Model Number	Description
232CL2R	REV CURR LOOP CONV

### Orders will be accepted and shipped until the following dates

Last Time Buy:	April 1 <sup>st</sup> , 2012
Last Time Ship:	April 30 <sup>th</sup> , 2012

The replacement product is not an exact match. Please refer to the attached documentation for differences.

Contact us immediately if you have any special needs for this product or have any other concerns.

Thank You,

Brian Foster, Product Manager  
[bfoster@bb-elec.com](mailto:bfoster@bb-elec.com)

# Current Loop Converter Model 232CL2

Document No. 232CL24895

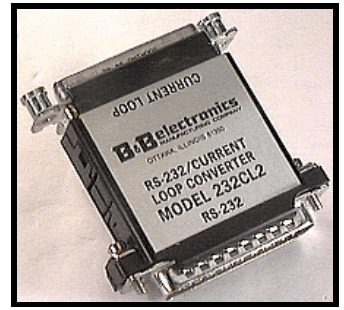

This B&B converter inputs RS-232 Transmit Data (2) and outputs 20 ma current loop signals, T+ and T-. The device also inputs current loop signals, R+ and R-, and outputs RS-232 Receive Data (3). High speed optical isolators couple and isolate the TD and RD.

The following information will help you make your interconnection:

1. **Connectors.** The 232CL2 uses a male DB25P connector for the RS-232 interface and a female DB25S connector for the current loop interface.
  
2. **Power for the Converter.** The Model 232CL2 is designed to use +/- 12 Volts from pins 4, 5, 6, 8 and 20 to power the RS-232 side of the unit. One of these pins must be high and one must be low for the unit to work. These lines will not be necessary if you are converting in one direction only, RS-232 to current loop, and you do not need to convert from current loop to RS-232. **NOTE: When using an external supply, the supply should be connected only to specifically labeled power inputs (power jack, terminal block, etc.). Connecting an external power supply to the handshake lines may damage the unit. Contact technical support for more information on connecting an external power supply to the handshake lines.**
  
3. **Current Loop Power.** The unit will operate with active or passive current loop ports, and no power is required on the current loop side of the converter if you port is active. If your current loop port is passive (does not have power), an external power supply of about 12 Volts DC must be wired to pins 9 and 21. (See figure). These pins are connected to resistors inside the converter and are used to create the 20 ma. current source. Through-hole resistors R11 and R12 allow you to create a current loop other than 20 ma.

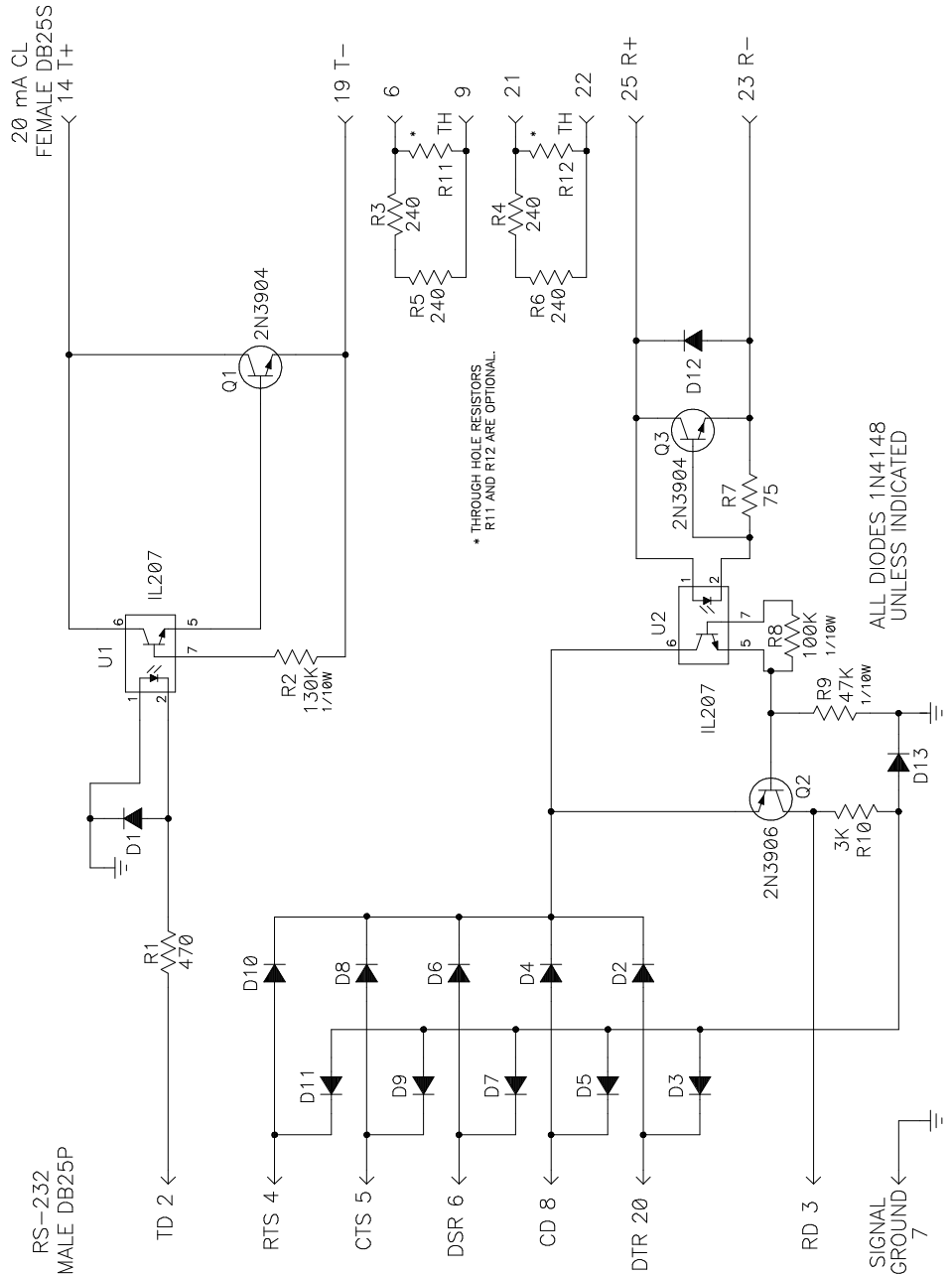

© B&B Electronics November 1995

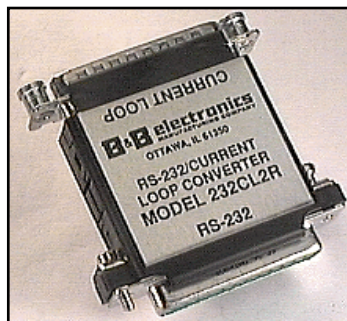

## Model: 232CL2R Reversed Current Loop Connector

The following information will help you make your interconnection:

- Connectors.** The 232CL2R uses a female DB25S connector for the RS-232 interface and a male DB25P connector for the current loop interface.
- Power for the Converter.** The Model 232CL2R is designed to use +/- 12 Volts from pins 4, 5, 6, 8 and 20 to power the RS-232 side of the unit. One of these pins must be high and one must be low for the unit to work. These lines will not be necessary if you are converting in one direction only, RS-232 to current loop, and you do not need to convert from current loop to RS-232. **NOTE: When using an external supply, the supply should be connected only to specifically labeled power inputs (power jack, terminal block, etc.). Connecting an external power supply to the handshake lines may damage the unit. Contact technical support for more information on connecting an external power supply to the handshake lines.**
- Current Loop Power.** The unit will operate with active or passive current loop ports, and no power is required on the current loop side of the converter if you port is active. If your current loop port is passive (does not have power), an external power supply of about 12 Volts DC must be wired to pins 9 and 21 (see figure). These pins are connected to resistors inside the converter and are used to create the 20 ma. current source. Through-hole resistors R11 and R12 allow you to create a current loop other than 20 ma.

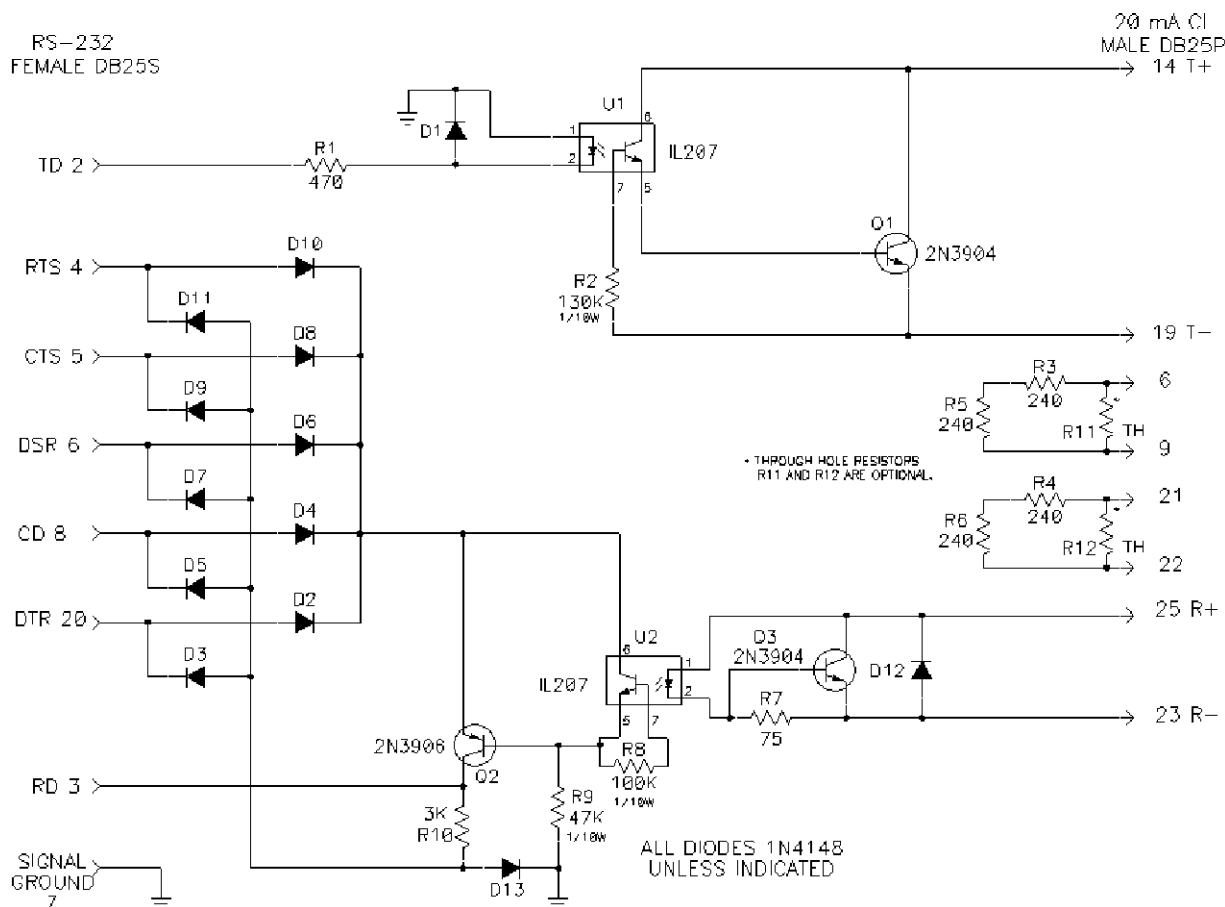

International Headquarters:

**B&B Electronics Mfg. Co.** 707 Dayton Road P.O. Box 1040 Ottawa, IL 61350 USA  
815-433-5100 Fax 433-5104 [www.bb-elec.com](http://www.bb-elec.com) [orders@bb-elec.com](mailto:orders@bb-elec.com) [support@bb-elec.com](mailto:support@bb-elec.com)

**B&B Electronics Ltd** Westlink Commercial Park Oranmore Co. Galway Ireland  
+353 91 792444 Fax +353 91 792445 [www.bb-europe.com](http://www.bb-europe.com) [orders@bb-elec.com](mailto:orders@bb-elec.com) [support@bb-europe.com](mailto:support@bb-europe.com)