

Product End of Life Notification

Date: September 28th, 2011

Product Being Discontinued

Model Number	Description
422LP9TB	PORT PWR 9P 232/422 CONVERTER

Replacement Product

Model Number	Description
422PP9TB	PORT POWERED 9PIN 232/422 CONV

Orders will be accepted and shipped until the following dates

Last Time Buy:	November 21 st , 2011
Last Time Ship:	December 30 th , 2011

Please contact us immediately if you have any special needs for this product or have any other concerns.

Thank You,

Brian Foster, Product Manager
bfoster@bb-elec.com



Model 422PP9TB Port-Powered RS-232 to RS-422 Converter

The 422PP9TB is a port-powered two-channel RS-232 to RS-422 converter. It converts TD and RD RS-232 lines to balanced RS-422 signals. The unit can be powered from the RS-232 handshake lines, DTR and RTS. If port-powering the unit, at least one of these handshake lines must be present, but can be in any state. The 422PP9TB can also be powered externally on the terminal blocks. The RS-422 driver and receiver are always enabled.

To satisfy the requirements of some software packages, the RS-232 handshake lines are looped back (tied together). RTS is connected to CTS, and DTR is connected to DSR and DCD.

Connections

The 422PP9TB is configured to transmit both directions between an RS-232 and RS-422 system. The RS-232 side is pinned out to connect directly into the COM port on your computer or any other DTE device (Table 1). Connections to the RS-422 side of the converter are made through terminal blocks. When connecting to an RS-422 system, the 422PP9TB **must** be connected with the proper polarity as shown in Figure 1. When no data is being sent and the driver enabled, the RS-232 line is negative and the RS-422 line TD(A) is negative with respect to TD(B).

Signal	DB-9 Female Pin #
TD	3
RD	2
RTS	7
CTS	8
DTR	4
DSR	6
DCD	1
GND	5

Figure 1 - Connection to an RS-422 System

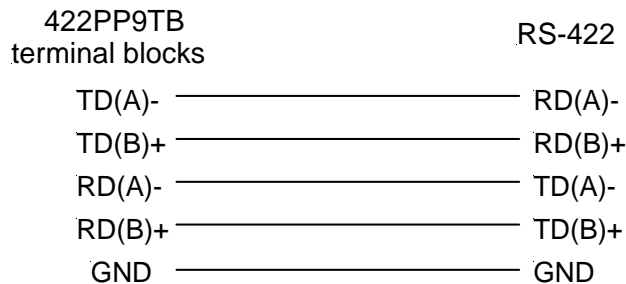

International Headquarters: 707 Dayton Road PO Box 1040 Ottawa, IL 61350 USA
815-433-5100 Fax 433-5104 www.bb-elec.com orders@bb-elec.com support@bb-elec.com

European Headquarters: Westlink Commercial Park Oranmore Co. Galway Ireland
+353 91 792444 Fax +353 91 792445 www.bb-europe.com orders@bb-elec.com support@bb-europe.com

Biassing Resistors

The biasing resistors for the RS-422/RS-485 receiver are 4.7k Ohm resistors. These resistors are labeled R1 and R2 (See Figure 2). Refer to B&B Electronics RS-422/485 Application Note for further information on biasing.

Figure 2

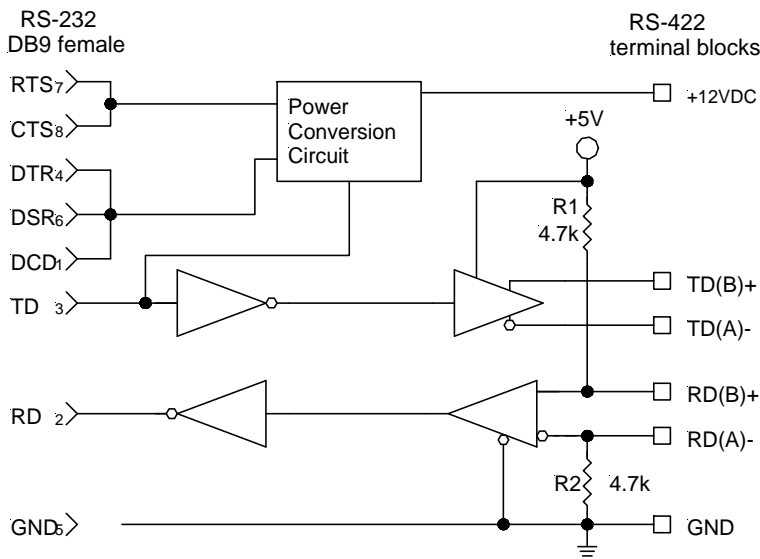

Specifications

Communication:	RS-422
Data Rate:	115.2 kbps max.
Power:	Port-powered from handshake lines on the RS-232 side, or 12 to 16 VDC at 40 mA on the terminal blocks.
Dimensions:	3.5 x 1.3 x 0.7 in (8.9 x 3.3 x 1.7 cm)
Temperature Rating:	0 to 70°C

NOTE: When using an external supply, the supply should be connected only to specifically labeled power inputs (power jack, terminal block, etc.). Connecting an external power supply to the handshake lines may damage the unit. Contact technical support for more information on connecting an external power supply to the handshake lines.

DECLARATION OF CONFORMITY

Manufacturer's Name:	B&B Electronics Manufacturing Company
Manufacturer's Address:	P.O. Box 1040 707 Dayton Road Ottawa, IL 61350 USA
Model Number:	422PP9TB
Description:	9-Pin Port-Powered RS-422 Converter
Type:	Light industrial ITE equipment
Application of Council Directive:	89/336/EEC
Standards:	EN 55022 EN 61000-6-1 EN 61000 (-4-2, -4-3, -4-4, -4-5, -4-6, -4-8, -4-11)

Robert M. Paratore, Director of Engineering



B&B electronics
MANUFACTURING COMPANY

International Headquarters: 707 Dayton Road PO Box 1040 Ottawa, IL 61350 USA
815-433-5100 Fax 433-5104 www.bb-elec.com orders@bb-elec.com support@bb-elec.com

European Headquarters: Westlink Commercial Park Oranmore Co. Galway Ireland
+353 91 792444 Fax +353 91 792445 www.bb-europe.com orders@bb-elec.com support@bb-europe.com

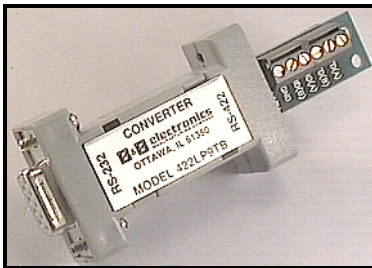

Model 422LP9TB Two Channel RS-232 to RS-422 Converter **CE**

The 422LP9TB is a port-powered two-channel RS-232 to RS-422 converter. It converts TD and RD RS-232 lines to balanced RS-422 signals. The unit can be powered from the RS-232 handshake lines, DTR and RTS. If port powering the unit, one of these handshake lines must be asserted (high) in order to power the unit (See Table 1). The RS-422 driver is enabled when RTS is asserted. Therefore, RTS must be asserted in order to transmit data. The RS-422 receiver is always enabled. If DTR is always asserted and the RTS is used to control the driver, the 422LP9TB can be used as an RS-232 to RS-485 4-wire converter. To insure reception, it is recommended that DTR is asserted (or power the unit externally).

In order to maximize the amount of power available to the RS-422 driver, the RS-232 **handshake lines are not looped back** (tied together). As a result the following handshake lines will appear as disasserted (low): CTS, DCD, and DSR. Care should be taken to insure that any software being used doesn't require any of these handshake lines be asserted. If existing software requires any of the handshake lines to be asserted, you can loop back the required handshake lines in your cable.

Table 1

RTS State	DTR State	Functions Possible (when port powering unit)
Low	Low	none
Low	High	Receive
High	Low	Transmit, Receive
High	High	Transmit, Receive

* NOTE: Low = disasserted and High = asserted

Connections

The 422LP9TB can be connected in three different type of systems: RS-422 (Figure 1), four-wire RS-485 (Figure 1), and two-wire RS-422 (Figure 2). Regardless of the system, the 422LP9TB must be connected with the proper polarity. With no data is being sent and the driver enabled, the RS-232 line should be negative and the TD(A) should be negative with respect to TD(B).

Proper operation of any RS-422 system requires the presence of a signal return path between the signal grounds of the equipment at each end of an interconnection. This circuit reference may be established by a third conductor connecting the common leads of devices, or it may be provided by connections in each piece of equipment to an earth reference. When the circuit reference is provided by a third conductor, the connection between the signal grounds and the third conductor should contain some resistance (e.g. 100 Ohms) to limit circulating currents when other ground connections are provided for safety.

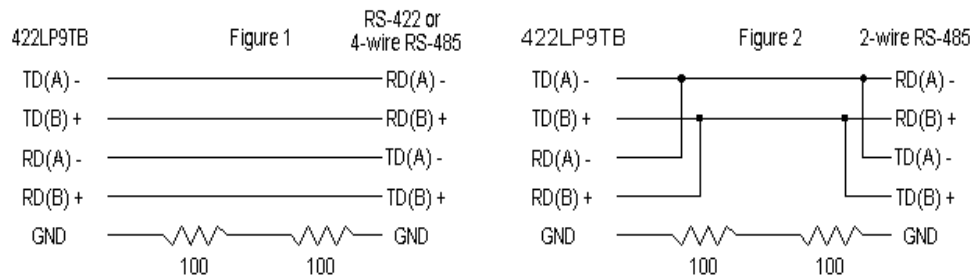

International Headquarters:

B&B Electronics Mfg. Co. 707 Dayton Road P.O. Box 1040 Ottawa, IL 61350 USA
815-433-5100 Fax 433-5104 www.bb-elec.com orders@bb-elec.com support@bb-elec.com

B&B Electronics Ltd Westlink Commercial Park Oranmore Co. Galway Ireland
+353 91 792444 Fax +353 91 792445 www.bb-europe.com orders@bb-elec.com support@bb-europe.com

Biasing Resistors

The biasing resistors for the RS-422/RS-485 receiver are 4.7K Ohm resistors. These resistors are labeled R1 and R6 (See Figure 3). Refer to B&B Electronics RS-422/485 Application Note for further information on biasing.

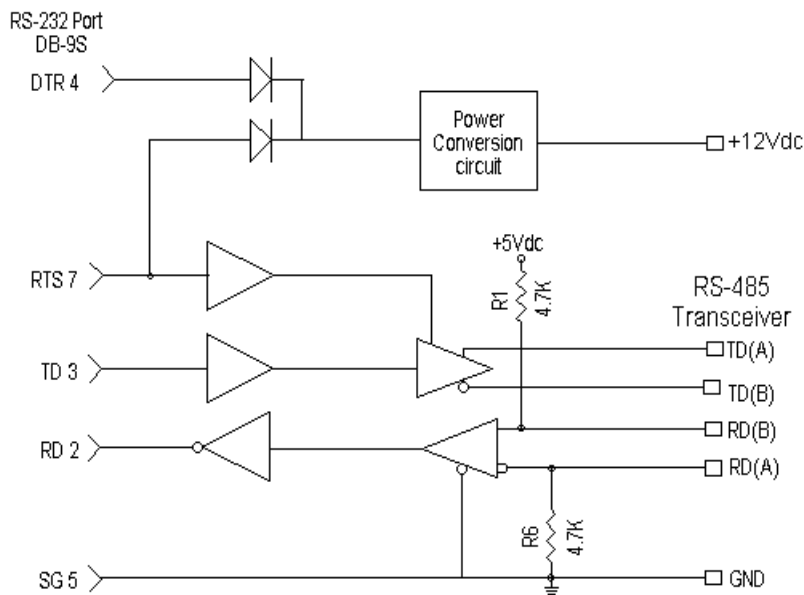

Figure 3

Specifications

Data Rate: 115.2K Baud max.

Power: Port Powered from RTS and DTR.

Note: If external power is required, use a source that can supply 12 to 16VDC at 40mA

NOTE: When using an external supply, the supply should be connected only to specifically labeled power inputs (power jack, terminal block, etc.). Connecting an external power supply to the handshake lines may damage the unit. Contact technical support for more information on connecting an external power supply to the handshake lines.

DECLARATION OF CONFORMITY

Manufacturer's Name:	B&B Electronics Manufacturing Company
Manufacturer's Address:	P.O. Box 1040 707 Dayton Road Ottawa, IL 61350 USA
Model Numbers:	422LP9TB
Description:	9-Pin Port-Powered RS-422 Converter
Type:	Light industrial ITE equipment
Application of Council Directive:	89/336/EEC
Standards:	EN 55022 EN 61000-6-1 EN 61000 (-4-2, -4-3, -4-4, -4-5, -4-6, -4-8, -4-11)

William H. Franklin III, Director of Engineering



International Headquarters:

B&B Electronics Mfg. Co. 707 Dayton Road P.O. Box 1040 Ottawa, IL 61350 USA
815-433-5100 Fax 433-5104 www.bb-elec.com orders@bb-elec.com support@bb-elec.com

B&B Electronics Ltd Westlink Commercial Park Oranmore Co. Galway Ireland
+353 91 792444 Fax +353 91 792445 www.bb-europe.com orders@bb-elec.com support@bb-europe.com