

# **RS-485 to RS-485 Optical Isolator/Repeater**

## **Model 485OPIN**

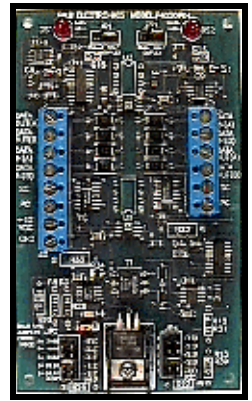

### **Description:**

The 485OPIN can be used to optically isolate one piece of RS-485 equipment from the rest of an RS-485 system, or one local group of RS-485 equipment from another. It can also be used as an RS-485 repeater to expand an existing RS-485 system to greater than the 32 node limitation in the RS-485 Standard. A typical setup using the 485OPIN as an RS-485 repeater is shown in Figure 1.

All data lines as well as power and ground are isolated from one side of the 485OPIN to the other. The 485OPIN uses terminal blocks on each side of the device. It supports Transmit Data (A) and (B), Receive Data (A) and (B), Protective Ground, and Signal Ground.

### **Connection:**

The 485OPIN can operate in either two-wire half-duplex systems or in four-wire half-duplex or full-duplex systems (see Figures 2 and 3). The 485OPIN can also operate as a four-wire to two-wire converter. By connecting one side of the 485OPIN as a two-wire device and one side as a four-wire device, equipment meant for a point-to-point RS-422 interface can be connected directly to an RS-485 two-wire multi-drop system.

Proper operation of any RS-485 system requires the presence of a signal return path. The RS-485 Standard recommends that a third wire be used for this. For safety, a 100 ohm resistor should be connected between frame ground and signal ground at every drop point. For the transient suppression of the 485OPIN to work properly, the protective ground (PG) terminal must be tied to a good frame (chassis, green wire, or earth) ground.

No wire type or maximum run length is listed in the RS-485 Standard. However, the RS-422 Standard, which is very similar, recommends number 24AWG twisted pair telephone cable with a shunt capacitance of 16 pF per foot and no more than 4000 feet of distance.

### **Operation:**

When no data is being transmitted through the 485OPIN, the receivers are enabled on both sides of the device. As data is received on one side of the 485OPIN, the opposite driver is enabled. When the 485OPIN receives the falling edge of the last data bit, it waits one character time to disable the driver. This time-out period is factory preset for one millisecond to accommodate a baud rate of 9,600 bits per second. The time-out period can be changed to any value between 0.26 and 4.16 milliseconds by removing the cover and moving the jumpers JP2 and JP4 inside the 485OPIN. The preset jumper settings available on the 485OPIN should accommodate almost all systems, but a different time-out can be achieved by putting JP2 and JP4 in position E and changing the values of the capacitors C6 and C9 and resistors 17 and 25. Spaces for through-hole replacement of these components are also provided. They are labeled C15, C16, R26, and R27. R32 and R33 allow for the addition of optional termination resistors at each receiver. The jumper positions for various baud rates, as well as the resistor and capacitor values for time-out periods beyond this range are given in Table 1. See Figure 4 for the location of the timing components.

Jumpers JP1 and JP3 determine whether the receivers will be disabled when transmitting (half-duplex) or always enabled (full-duplex). As a general rule, JP1 and JP3 should be in the half-duplex position for two-wire operation and in the full-duplex position for four-wire systems. See Figure 4 for the location of jumpers JP1-JP4 on the PC board.

### **Specifications:**

Isolation:	2,000 volts RMS for 1 min. optical isolation of data lines and ground.
Surge Suppression:	6.5V working peak voltage, bi-directional over voltage suppresser. 600W peak power dissipation. 3,000 pF maximum capacitance.
Data Rates:	Up to 460.8K baud.
Operating Temperature:	-40°C to +85°C
Power Requirements:	9-14V DC @ 60mA (idle state), 170mA (full-duplex data with 62 Ohm load).
Dimensions:	2.75"L x 4.6"W

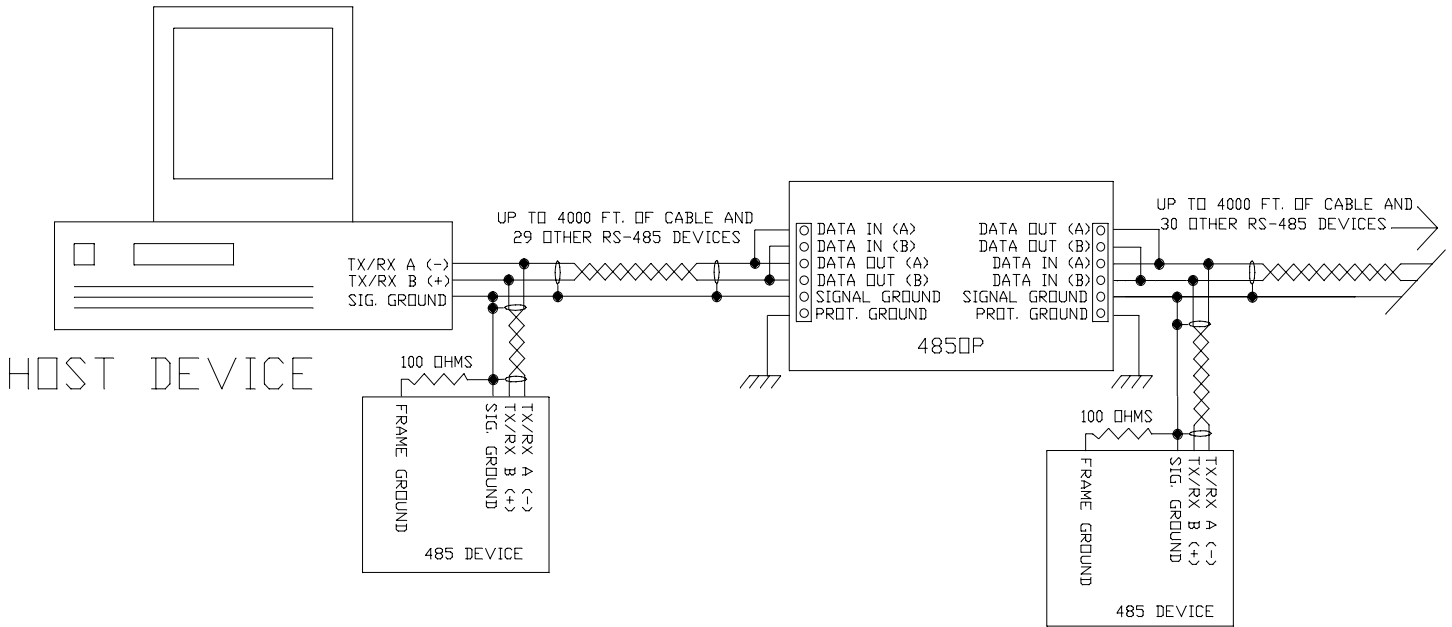

FIGURE 1. 485OPIN As A Two-Wire Repeater

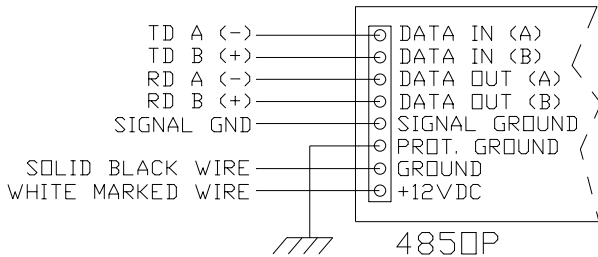

FIGURE 2. Four-Wire Setup

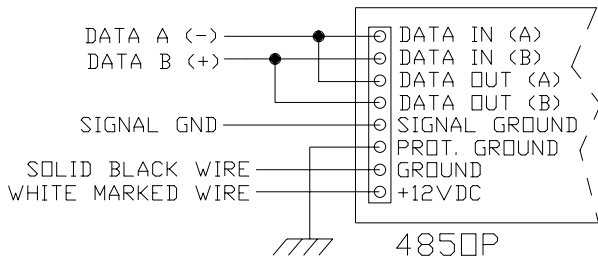

FIGURE 3. Two-Wire Setup

Table 1				
APPROXIMATE TIMEOUT VALUES				
Baud Rate	Time (ms)	Resistor R17 & R25 (ohm)	Capacitor C6 & C9 (mfd)	Jumper Position JP2 & JP4
300	33.3	330K	0.1	-
600	16.6	160K	0.1	-
1200	8.33	820K	0.01	-
2400	4.16	430K	0.01	A
4800	2.08	200K	0.01	B
9600	1.04	100K	0.01	C
19.2K	0.52	56K	0.01	D
38.4K	0.26	27K	0.01	E
57.6K	0.18	16K	0.01	-
115.2K	0.087	8.2K	0.01	-

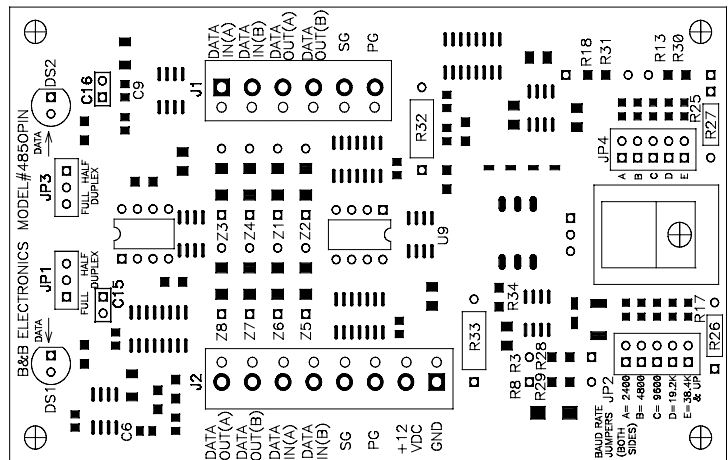

FIGURE 4. PC Board Layout

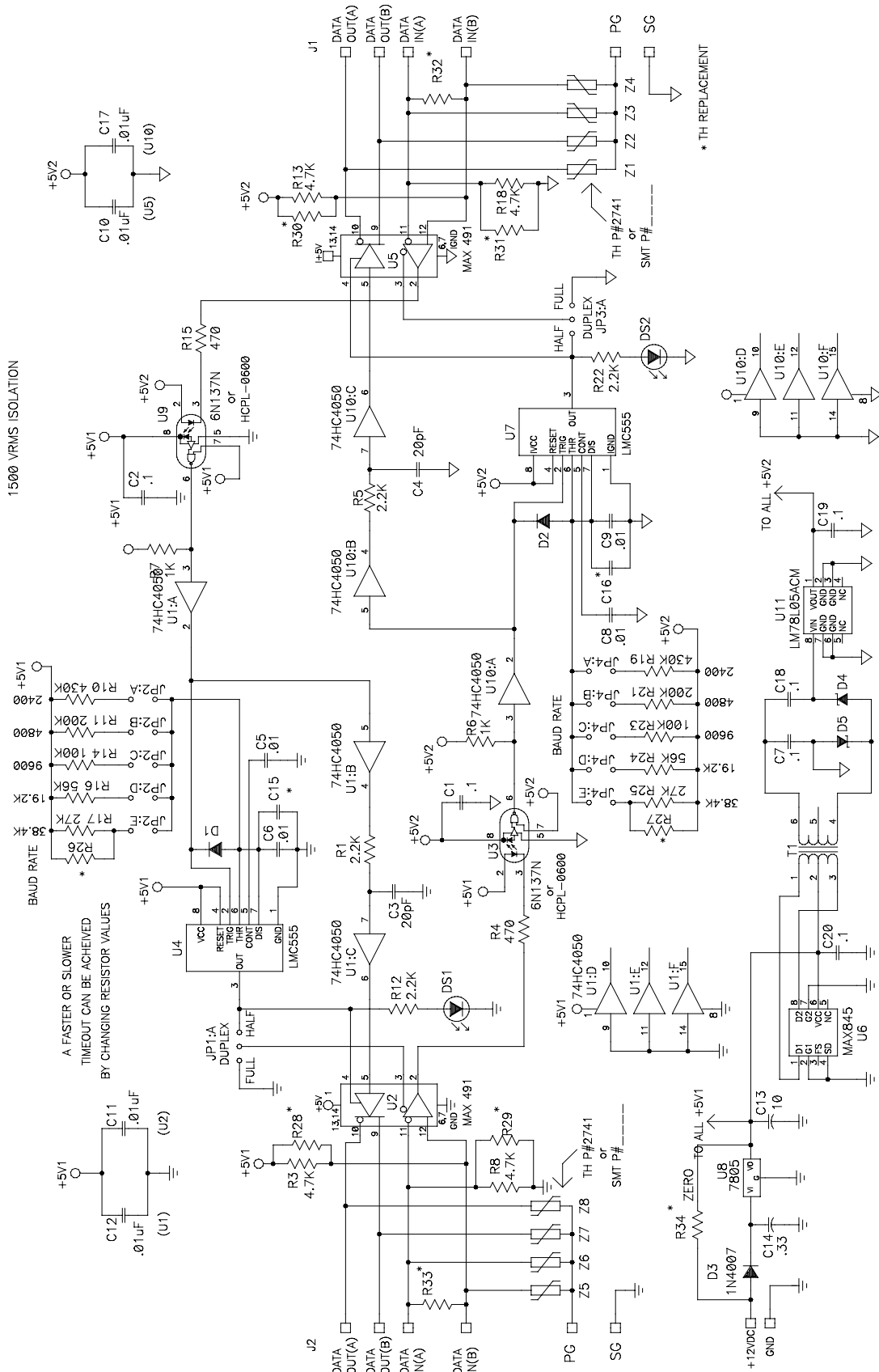

FIGURE 5. Circuit Diagram

© B&B Electronics July 1996 -- Revised July 2002

Phone: (815) 433-5100  
 Office Fax: (815) 433-5105  
 Tech Fax: (815) 433-5104  
 Sales Fax: (815) 433-5109

**B&B electronics**  
 MANUFACTURING COMPANY  
 707 Dayton Road -- P.O. Box 1040 -- Ottawa, IL 61350 USA

Home Page: [www.bb-elec.com](http://www.bb-elec.com)  
 E-mail: [orders@bb-elec.com](mailto:orders@bb-elec.com)  
[support@bb-elec.com](mailto:support@bb-elec.com)  
[catrqt@bb-elec.com](mailto:catrqt@bb-elec.com)