

RS-232 Baud Rate Converter €

Model 232BRC

Documentation Number 232BRC-1005

pn5104-r004

B & B Electronics

International Headquarters

B&B Electronics Mfg. Co. Inc.

707 Dayton Road -- P.O. Box 1040 -- Ottawa, IL 61350 USA

Phone (815) 433-5100 -- General Fax (815) 433-5105

Home Page: www.bb-elec.com

Sales e-mail: orders@bb-elec.com -- Fax (815) 433-5109

Technical Support e-mail: support@bb-elec.com -- Fax (815) 433-5104

European Headquarters

B&B Electronics

Westlink Commercial Park, Oranmore, Co. Galway, Ireland

Phone +353 91 792444 -- Fax +353 91 792445

Home Page: www.bb-europe.com

Sales e-mail: orders@bb-europe.com

Technical Support e-mail: support@bb-europe.com

© B&B Electronics – Revised February 2005

TABLE OF CONTENTS

Chapter 1: INTRODUCTION	3
Applications	3
Specifications	4
Default Parameters	4
Checklist.....	5
Chapter 2: OPERATION	7
Port Configurations.....	7
Port Connections.....	9
LED Indicators.....	11
Chapter 3: SETUP SOFTWARE	13
Introduction.....	13
Connection	13
Software Installation	14
Software Uninstall	14
Setup Tutorial	14
Main Screen	15
Copying Parameters Between Units	16
Final System Installation	17
Default Parameters	17
Appendix A: Cable Charts	A-1
Port A Connections	A-1
Chart A.1. DTE (PC) DB9 to Port A (DCE)	A-1
Chart A.2. DTE (PC) DB25 to Port A (DCE)	A-1
Chart A.3. DCE (Modem) DB9 to Port A (DCE).....	A-2
Chart A.4. DCE (Modem) DB25 to Port A (DCE).....	A-2
Port B Connections	A-2
Chart A.5. DCE (Modem) DB9 to Port B (DTE)	A-2
Chart A.6. DCE (Modem) DB25 to Port B (DTE)	A-3
Chart A.7. DTE (PC) DB9 to Port B (DTE).....	A-3
Chart A.8. DTE (PC) DB25 to Port B (DTE).....	A-3
Appendix B: Block Diagram	B-1
Appendix C: Declaration of Conformity	C-1

Chapter 1: INTRODUCTION

The 232BRC acts as a translator between devices with incompatible asynchronous serial communications. Each port uses a dedicated UART and includes a 16 kbyte receive buffer. Each port can be independently configured for data rate, data format, and handshaking.

Each side of the 232BRC can be configured to match the connected device. It supports any data rate up to 115.2 kbps and all standard data formats. Each side can either supply or accept hardware or software handshaking. Setup parameters are configured through the PC setup software provided and saved in non-volatile memory.

The 232BRC is supplied with two DB9 connectors. The female connector is configured as a DCE for connecting to PCs, Terminals, and other DTE devices. The male connector is configured as a DTE for connecting to Modems and other DCE devices. Three LEDs indicate power and the presence of data in either port's buffer.

Applications

- Connect devices with different data rates.
- Convert from hardware to software handshaking.
- Convert between data formats.
- Add handshaking to a streaming device.
- Use as a port buffer to increase throughput.

Specifications

Model:	232BRC
Interface:	RS-232 Asynchronous
Data Bits:	5, 6, 7, or 8
Parity:	Even, Odd, or None
Data Rate:	300 to 115.2 kbps
Stop Bits:	1 or 2
Flow Control:	Hardware(RTS/CTS), Software(XON/XOFF), or None
Buffer Memory:	16 Kbytes SRAM per port
LEDs:	Buffer A, Buffer B, Power
Power Requirements:	+12 to +17 VDC @ 60mA max.
Power Connector:	2.5mm Phono Jack (+ Tip)
Recommended Supply:	B&B Model 232PS
Data Connectors:	Port A DB9 Female Port B DB9 Male
Dimensions:	5.8 x 3.6 x 1.2 in. (14.6 x 9.1 x 3.0 cm)
Setup Software:	PC compatible, Windows 95/98/NT/2000
Supplied Accessories:	Software Instruction Manual

Default Parameters

When shipped, the 232BRC comes set up for the following parameters for ports A and B:

Data Rate = 9600 bps
Data Bits = 8
Stop Bits = 1
Parity = None
Handshaking = None

Refer to the following sections of the manual for what each of these parameters means and how they can be changed.

Checklist

Examine the shipping carton and contents for physical damage.
If damage is found, file a claim with the shipper immediately.

The following equipment should be in the shipping carton:

1. RS-232 Baud Rate Converter model 232BRC
2. Instruction Manual
3. Software

If any of the items above are not in the shipping carton contact the shipper immediately.

Chapter 2: OPERATION

Each port receives data from its connected device, buffers the data, and sends it out the opposite port when that port's handshaking indicates it is ready to receive data. Each port is set to match the requirements of its connected device through the setup software.

Unused output handshake lines are held high by the 232BRC. Pin 6 (DSR) on Port A and Pin 4 (DTR) on Port B are held in a constant true state. This provides a constant enabled signal to connected devices that need it, or provides a positive voltage to devices that derive their power from these lines.

Port Configurations

The 232BRC provides a dedicated UART to ports A and B. This allows each port to be individually configured for baud rate, number of data bits, parity, and hardware (RTS/CTS) or software (XON/XOFF) handshaking. Configuration parameters are set through the setup software.

Baud rate:

Each port supports the following standard baud rates:

300
600
1200
2400
4800
9600
19.2k
38.4k
57.6k
or 115.2 kbps

In addition, non-standard baud rates between 300 and 115.2 kbps can also be set. The 232BRC uses a 1.152 MHz clock for its base data rate, so any rate that can be evenly divided into 1.152 MHz can be set exactly.

For example:

$$28.8 \text{ kbps} = 1.152 \text{ MHz} / 40$$

Baud rates that are not evenly divisible into 1.152 MHz can also be used, but the actual baud rate will vary slightly from the requested rate. This may or may not cause data errors, depending on the attached equipment. Most standard UARTs can accept a 5% to 10% difference in baud rate before errors occur.

For example:

$$\text{Desired Baud Rate} = 20 \text{ kbps}$$

$$1.152 \text{ MHz} / 20 \text{ kbps} = 57.6$$

$$\text{Actual Rate} = 1.152 \text{ MHz} / 58 = 19.862 \text{ kbps}$$

$$\% \text{error} = (20 \text{ kbps} - 19.862 \text{ kbps}) / 20 \text{ kbps} * 100$$

$$\% \text{error} = 0.7\%$$

Data bits:

Each port can be configured for Five, Six, Seven or Eight data bits. **NOTE:** If the ports are set up differently, the port set for fewer data bits cannot transmit the upper most significant bits.

Parity:

Each port can be configured for Even, Odd, or No parity. The parity should be selected to match the connected device.

Stop Bits:

Each port can be configured for one or two stop bits. The stop bits should be selected to match the connected device.

Flow Control:

Hardware(RTS/CTS) Handshaking:

Each port can be independently configured to hold data until its input handshake line goes high. On Port A, pin seven (RTS) would have to be held high by the connected device in order for the 232BRC to send data. On Port B, pin eight (CTS) needs to be held high by the connected device for the 232BRC to send data.

Connected devices can prevent data from being sent from the 232BRC by holding their corresponding handshake lines low. This corresponds to pin seven on Port A and pin eight on Port B. See Appendix A for a complete table of signal directions.

Software(XON/XOFF) Handshaking:

Each port can be independently configured for software handshaking. Software handshaking is normally used in communications links where the main data stream is one way, such as to a printer. The main sending device is expected to hold off its data when it receives the XOFF(13 Hex) character, and resume sending when it receives an XON(11 Hex). The main receiving device is expected to send the XOFF character if the buffer is full or it otherwise needs to hold off the data.

The 232BRC can be set to emulate either the main sending device or the receiving device. It can either supply the XON/XOFF handshake or stop sending data with the XON/XOFF. The port would normally be set to supply the XON/XOFF characters if it is connected to a fast sending device. It would be set to receive the XON/XOFF handshaking if the port is connected to the slower receiving device.

Port Connections

In order to determine the proper port connections to the 232BRC, it is necessary to have a basic understanding of the terms DCE and DTE. RS-232 was designed, using DB-25 connectors, for connecting a DTE (**D**ata **T**erminal **E**quipment) device to a DCE (**D**ata **C**ommunication **E**quipment) device. Each device will have inputs on pins that correspond to outputs on the same pins of the other device. For example, a DTE device will transmit data out on pin 2 (on a DB-25) and a DCE device will receive data in on pin 2 (on a DB-25). IBM PCs and serial printers are DTE devices, modems are DCE devices.

Originally the RS-232 Standard specified only a 25 pin, D-sub connector. Since then, the use of a 9 pin, D-sub supporting only a portion of the original RS-232 signals has been used extensively, starting with the IBM PC and migrating into other peripherals. The pin outs for this 9 pin connector have since become the EIA/TIA 574 Standard. This standard specifies a DTE device that transmits on pin 3 and receives on pin 2, with the DCE having the opposite configuration. Figure 2.1 shows the signal direction for 25 pin and 9 pin devices configured as a DTE and DCE.

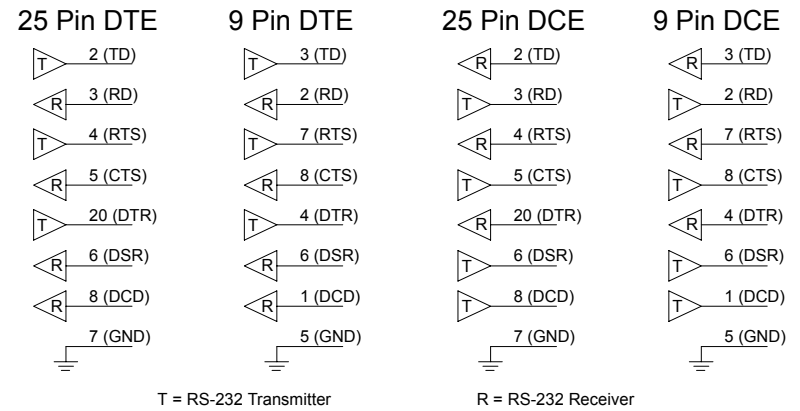

Figure 2.1. DTE/DCE Port Diagrams

Port A Connections

Port A of the 232BRC is a 9 pin, female D-sub connector configured as a DCE. This provides direct connection to an IBM PC compatible or other DTE device. If it is necessary to connect Port A to a modem or other device configured as a DCE, a null modem adapter or cable is needed.

See Appendix A for a complete set of connection tables to the 232BRC ports.

Port B Connections

Port B of the 232BRC is a 9 pin male D-sub connector configured as a DTE. This provides direct connection to a modem or other DCE device. If it is necessary to connect Port B to a PC or other device configured as a DTE, a null modem adapter or cable is needed.

See Appendix A for a complete set of connection tables to the 232BRC ports.

Power Connections

Power to the 232BRC is supplied through the 2.5mm Phono jack on the side of the unit (Tip Positive). The 232BRC has an integrated regulator, allowing it to operate on any supply voltage between +12 to +17 VDC. The 232BRC will draw 60 mA max.

LED Indicators

The 232BRC has three LED indicators. The first, labeled "POWER" indicates that power is applied to the converter. The other two, labeled "PORT A BUFFER" and "PORT B BUFFER" indicate that data is present in that port's receive buffer. Note that the buffer LEDs indicate buffered data only. If either device is fast enough to receive the data as fast as it can be sent, no data will be buffered, so the LED may not be lit.

Chapter 3: SETUP SOFTWARE

Introduction

The 232BRC comes with simple setup software for configuring the A and B ports. The software can run on any PC compatible computer using Microsoft Windows 95, 98, NT, or 2000 operating system.

Once the ports are configured, all parameters are saved in non-volatile memory so the 232BRC can be powered down and used anywhere without the loss of configuration data. Configurations can also be saved to a file for setting up more than one 232BRC to the same configuration.

Connection

A serial (COM) port of the computer should be connected to Port A of the 232BRC. If the computer's serial port is a 9 pin D-sub, a straight through connection cable is required. If the computer's serial port is a 25 pin D-sub, the cable should be an XT to AT adapter cable such as B&B's model 232CAMR, or a cable that would normally be used with a modem. See Appendix A for a complete set of connection tables to the 232BRC ports.

Remove the screws (4) on the bottom of the 232BRC with a Phillips screwdriver. Remove the top cover. Install the setup jumper marked JP1. See Figure 3.1 diagram of the PCBD. Power up the 232BRC with the setup jumper installed to put the unit in setup mode.

NOTE: The setup software cannot recognize the connected unit if the setup jumper is not installed or if the jumper is installed after the 232BRC is powered up.

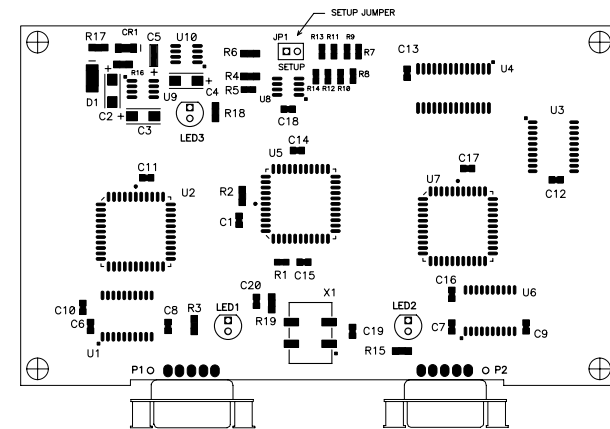

Figure 3.1 Setup Jumper Location

Software Installation

The setup software for the 232BRC must be installed on your hard drive before it can be run.

Software Uninstall

To remove the 232BRC setup software, follow these steps:

- Select **SETTINGS, CONTROL PANEL** from the Windows **START** menu.
- Double Click **ADD/REMOVE PROGRAMS**
- Select **232BRC SETUP** from the list of installed programs.
- Click the **ADD/REMOVE** button to remove the software components.

Setup Tutorial

Step 1: Start the software by double clicking the 232BRC Setup icon on the desktop.



Step 2: Select the serial (COM) port that will be used to configure the 232BRC.

Step 3: Connect the 232BRC Port A to the PC COM port selected. Install the setup jumper, and power up the 232BRC. When Next is clicked, the software reads the current configuration of the connected unit and displays the Main Screen.

Main Screen

All configuration of the 232BRC is done from the Main Screen. Each port's parameters can be individually selected and modified. Parameters can be selected from the drop-down lists. Any baud rate that is not in the list can be entered into the window.

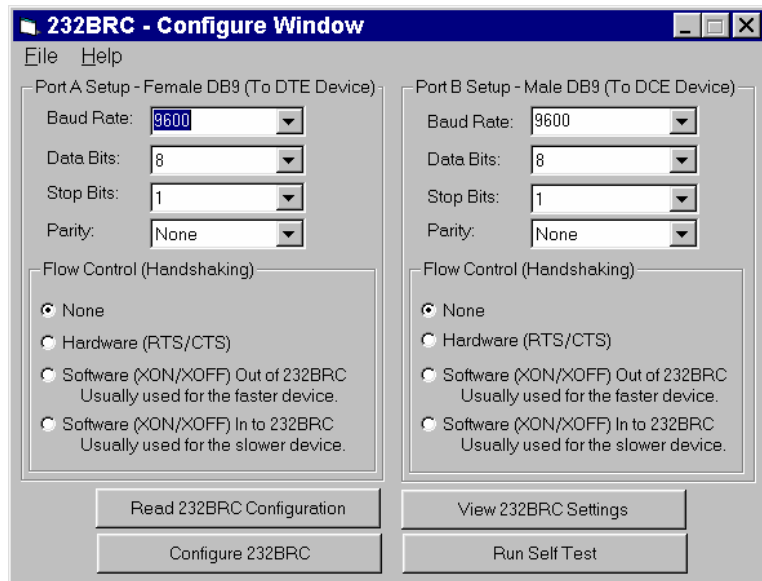

File Menu:

From the file menu, a configuration can be saved to disk, loaded from a disk, or printed. This provides an easy method of configuring multiple units with the same setup.

Read 232BRC Configuration Button:

This button will read the configuration from the connected 232BRC. The 232BRC is read upon entering the Main Screen, so it should not have to be read again unless it is necessary to set the parameters back after changing.

View 232BRC Settings Button:

This button will display all current port parameters of the connected unit on one screen for review. Any changes to the currently connected unit that have not been saved will be shown in Red. The page can then be printed for review or for attachment to the 232BRC.

Configure 232BRC Button:

This button will save all changes to the connected unit.

NOTE: Once changes are saved to the 232BRC they cannot be reset automatically. Be sure to review all changes before saving using the View Module Configuration button.

Run Self Test Button:

The 232BRC is programmed with a Self Test mode. The microprocessor checks the UARTs, RAM, and EEPROM and reports any errors back to the setup software. If the software reports an error, contact B&B Technical Support.

Copying Parameters Between Units

The 232BRC setup software can save configuration data to a file for copying of parameters. Any 232BRC's configuration can be copied by first reading the data from one unit, then saving to another.

Step 1: Run the setup software.

Step 2: Select serial (COM) port to be used for programming.

Step 3: If the configuration to be used is already saved to a file, skip to Step 8.

Step 4: Connect the 232BRC to be copied to the serial (COM) port of the PC. Install the setup jumper. Apply power to the 232BRC.

Step 5: Click Next.

Step 6: Select Save As from the File menu. Save the configuration to disk.

Step 7: Disconnect the first 232BRC from the COM port.

Step 8: Connect the destination 232BRC to the serial (COM) port of the PC. Install the setup jumper. Apply power to the 232BRC.

Step 9: Select File/Load File and load the saved configuration.

Step 10: Click Configure 232BRC

Once the configuration file has been loaded, any number of 232BRC modules can be set to the same parameters by connecting and configuring each in turn.

Final System Installation

After successfully completing and testing the 232BRC configuration, remove the setup jumper. Place the unit back in the enclosure and re-insert the 4 Phillips screws.

NOTE: The 232BRC will not function properly until the setup jumper is removed.

Default Parameters

When shipped, the 232BRC comes set up for the following parameters for ports A and B:

Data Rate = 9600 bps

Data Bits = 8

Stop Bits = 1

Parity = None

Handshaking = None

Appendix A: Cable Charts

All charts give full pinouts. Only pins 2 & 3 are required for basic operation. Pins 7 and 8 are needed for hardware (RTS/CTS) handshaking. If the connected device requires DTR or DSR, these signals are available on pins 4 and 6 respectively. See Appendix B for a block diagram of the 232BRC.

Port A Connections

Chart A.1. DTE (PC) DB9 Connector to Port A (DCE)

DTE (PC) Serial Port DB9 Connector	Signal Direction	232BRC Port A (DCE) DB9F Connector
2	<-----	2 (RD)
3	----->	3 (TD)
4	----->	4 (DTR)
5	<----->	5 (GND)
6	<-----	6 (DSR)
7	----->	7 (RTS)
8	<-----	8 (CTS)

Chart A.2. DTE (PC) DB25 Connector to Port A (DCE)

DTE (PC) Serial Port DB25 Connector	Signal Direction	232BRC Port A (DCE) DB9F Connector
2	----->	3 (TD)
3	<-----	2 (RD)
4	----->	7 (RTS)
5	<-----	8 (CTS)
6	<-----	6 (DSR)
7	<----->	5 (GND)
20	----->	4 (DTR)

Chart A.3. DCE (Modem) DB9 Connector to Port A (DCE)

DCE (Modem) Serial Port DB9 Connector	Signal Direction	232BRC Port A (DCE) DB9F Connector
2	----->	3 (TD)
3	<-----	2 (RD)
4	<-----	6 (DSR)
5	<----->	5 (GND)
6	----->	4 (DTR)
7	<-----	8 (CTS)
8	----->	7 (RTS)

Chart A.4. DCE (Modem) DB25 Connector to Port A (DCE)

DCE (Modem) Serial Port DB25 Connector	Signal Direction	232BRC Port A (DCE) DB9F Connector
2	<-----	2 (RD)
3	----->	3 (TD)
4	<-----	8 (CTS)
5	----->	7 (RTS)
6	----->	4 (DTR)
7	<----->	5 (GND)
20	<-----	6 (DSR)

Port B Connections

Chart A.5. DCE (Modem) DB9 Connector to Port B (DTE)

DCE (Modem) Serial Port DB9 Connector	Signal Direction	232BRC Port B (DTE) DB9M Connector
2	----->	2 (RD)
3	<-----	3 (TD)
4	<-----	4 (DTR)
5	<----->	5 (GND)
6	----->	6 (DSR)
7	<-----	7 (RTS)
8	----->	8 (CTS)

Chart A.6. DCE (Modem) DB25 Connector to Port B (DTE)

DCE (Modem) Serial Port DB25 Connector	Signal Direction	232BRC Port B (DTE) DB9M Connector
2	<-----	3 (TD)
3	----->	2 (RD)
4	<-----	7 (RTS)
5	----->	8 (CTS)
6	----->	6 (DSR)
7	<----->	5 (GND)
20	<-----	4 (DTR)

Chart A.7. DTE (PC) DB9 Connector to Port B (DTE)

DTE (PC) Serial Port DB9 Connector	Signal Direction	232BRC Port B (DTE) DB9M Connector
2	<-----	3 (TD)
3	----->	2 (RD)
4	----->	6 (DSR)
5	<----->	5 (GND)
6	<-----	4 (DTR)
7	----->	8 (CTS)
8	<-----	7 (RTS)

Chart A.8. DTE (PC) DB25 Connector to Port B (DTE)

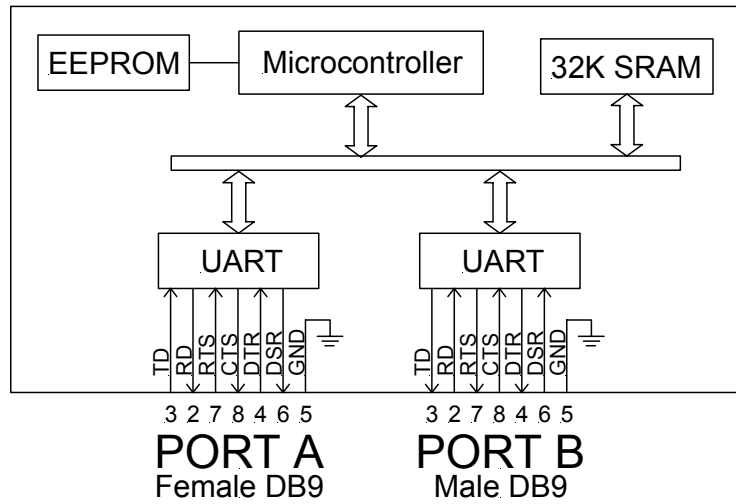

DTE (PC) Serial Port DB25 Connector	Signal Direction	232BRC Port B (DTE) DB9M Connector
2	----->	2 (RD)
3	<-----	3 (TD)
4	----->	8 (CTS)
5	<-----	7 (RTS)
6	<-----	4 (DTR)
7	<----->	5 (GND)
20	----->	6 (DSR)

Appendix B: Block Diagram



232BRC Block Diagram

Appendix C: Declaration of Conformity

DECLARATION OF CONFORMITY	
Manufacturer's Name:	B&B Electronics Manufacturing Company
Manufacturer's Address:	P.O. Box 1040 707 Dayton Road Ottawa, IL 61350 USA
Model Number:	232BRC
Description:	RS-232 Baud Rate Converter
Type:	Light industrial ITE equipment
Application of Council Directive:	89/336/EEC
Standards:	EN 55022 EN 61000-6-1 EN 61000 (-4-2, -4-3, -4-4, -4-5, -4-6, -4-8, -4-11)
	
Robert M. Paratore, Director of Engineering	