

Aegis Critical Load Filter (AGSVL) Installation and Operating Guide

Table of Contents

- 1.0 AGSVL Operation
- 2.0 Preparation
- 3.0 Installation Procedures
- 4.0 Specifications and Installation Drawings
- 5.0 Diagnostics
- 6.0 Maintenance
- 7.0 Warranty



Fig. 1 AGSVL

Introduction

AGSVL products are premium Surge Protection Devices (SPDs) with a hybrid MOV/filter design. They are applied to electronic equipment such as PLC, control equipment, RTU, etc. to prevent damage from loads voltage surges, spikes, and electrical line noise. Correct installation is critical for the proper operation of the AGSVL unit. Please read the installation and operating instructions prior to installing the AGSVL suppression device.

1.0 AGSVL Operation

Properly installed, AGSVL products will protect electronic equipment. They are installed in series with the load to be protected. Under normal operating conditions, the AGSVL will only draw a small capacitive current from the line. When a voltage surge or electrical line noise exists, the AGSVL will remove the portion of the disturbance that exceeds the system's normal operating voltage.

2.0 Preparation

Before installation, verify that the amperage and voltage ratings of the AGSVL match the application. The maximum amperage rating of the AGSVL is identified on the top cover in red. The amperage rating can also be found on the nameplate. The nameplate is located on the side of the AGSVL container. The maximum amperage of the protected load must be equal to or less than the AGSVL product. If the amperage rating is exceeded, the unit can overheat and fail.

To verify the voltage rating, check the nameplate on the side of the AGSVL container. The maximum voltage will be the same from Line to Neutral (L-N), Line to Ground (L-G), and Neutral to Ground (N-G). This makes the AGSVL suitable for floating systems that utilize L, L, G and bonded systems that are L, N, G. The amperage and voltage rating is also indicated in the catalog number. The catalog number can also be found on the nameplate.



Critical Load Powerline Filter	Rating	
	<u>Voltage</u>	<u>Amperage</u>
AGSVL	120N	01
	230L*	03
		05

*Applicable for 230/240V systems

Review the application to ensure physical space exists for the AGSVL product installation.

Review and check the grounding system. All grounding and bonding systems must meet NEC, CEC and/or applicable local codes to ensure reliable operation of electronic loads. A poor ground or grounding and bonding violations will seriously affect the AGSVL product's ability to function as specified.

The AGSVL input ground and output ground (where supplied) are internally wired together at the factory. Loads that require a separate ground must use the output ground from the AGSVL. Loads that are grounded to the chassis of the equipment do not require the output ground from the AGSVL to prevent ground loops. The AGSVL input ground should be connected to the local ground point in all installations.

Overcurrent protection is required to protect the distribution system from an unlikely failure of the AGSVL or downstream load. Overcurrent protection must be sized according to the downstream load with an additional margin for the AGSVL capacitive current draw. For 120 VAC systems at 50/60 Hz use an additional 1 ampere, for 220 to 240 VAC systems at 50/60 Hz use an additional 1.5 amperes. The ampere current draw of the AGSVL is capacitive and may increase if there is significant noise on the power line. This will not detract from the output current rating of the AGSVL as the current rating of the AGSVL is based on the output current only.

If fuses are utilized, Cutler-Hammer recommends slow acting fuses for loads with high inrush currents. The AGSVL is designed to withstand large inrush currents.

Alternatively, overcurrent protection can be installed for the AGSVL, sized as above, and for the load. This method is popular for low current applications.

3.0 Installation Procedures

For optimal protection, place the AGSVL product as close as possible to the load being protected. Cutler-Hammer recommends that the wiring from the AGSVL output terminals to the input terminals of the electronic equipment be kept as short and straight as possible. This will prevent the wiring from acting as an antenna that picks up high frequency noise from the environment. Wiring length to the input terminals of the AGSVL product is not critical.

Installation Drawings

1. To prevent the risk of electrical shock, TURN OFF and lock out all power sources to the electrical circuit where the AGSVL is to be installed. Verify that the power has been disconnected with a portable voltmeter or other measuring device.
2. Install overcurrent protection on the line side of the AGSVL.
3. If existing DIN-Rail is available, mount AGSVL to DIN-Rail. If not, use factory supplied DIN-Rail by installing to a desired location and then mount AGSVL to DIN-Rail.
4. Wire from the overcurrent protection to the input terminals of the AGSVL. The terminals are clearly marked L, N, and G. Wire gauge should be selected to match the amperage of the overcurrent protection. Generally, #14 AWG is used. Ensure that the proper color wire is used (green or green/yellow - ground, white or light blue - neutral, black and/or red - phase) and tighten all connections.
5. Wire from the AGSVL output terminals to the input terminals of the protected load. Tighten all connections.
6. Recheck all connections.
7. Restore power to the electrical circuit.
8. Check that the status indicator (Green LED) is illuminated.

4.0 Specifications and Installation Drawings

Specifications

Input Voltage.....	120V & 230V - 1ph(L,N,G or L,L,G)
Amperage.....	01, 03, & 05 AMP
Frequency Range	47 – 63 Hz
Protection Modes.....	L-N, L-G, & N-G
MCOV.....	150V & 320V
Noise Attenuation (Normal Mode)....	50dB @ 100 kHz
Filter Bandwidth.....	10 kHz to 50 MHz
Peak Surge Current.....	39kA/phase (L-N + L-G)
Internally Fused.....	Thermal Fuses
Fault Current Rating (AIC rating per UL).....	500A
Operating Temperature.....	-40 °C to + 50°C
Response Time	> one ns
Agency Approvals.....	UL 1449 2 nd Edition, CSA
Warranty.....	Five Years

TYPICAL OEM SYSTEM

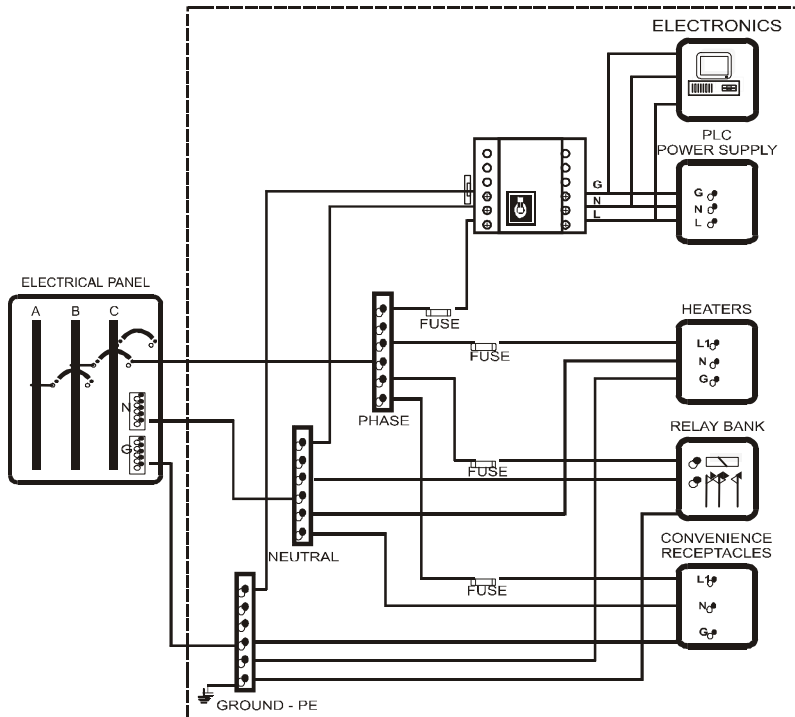

BONDED SYSTEM

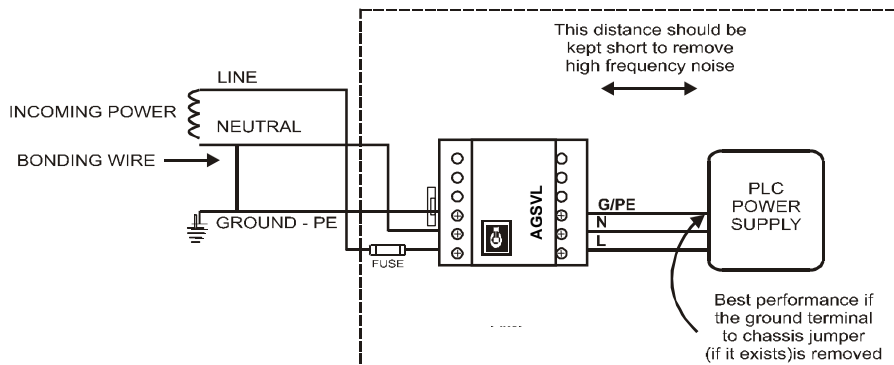

UNBONDED SYSTEM

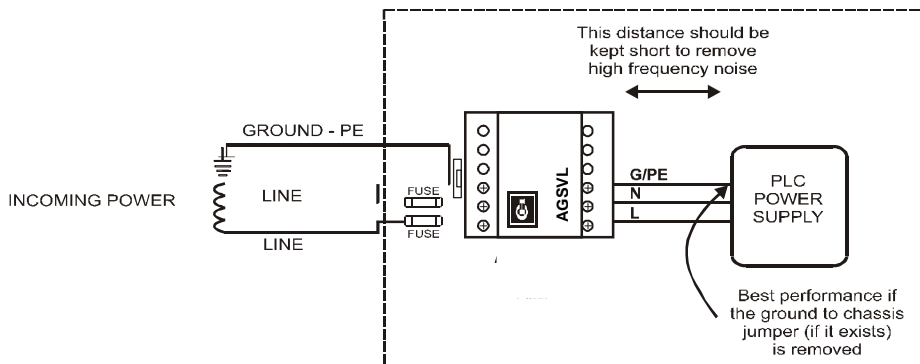

5.0 Diagnostics

The AGSVL is supplied with a green LED that will illuminate and indicate power at the output terminals. If the green LED is not illuminated, it indicates that power is not being supplied to the AGSVL. The LED will not illuminate if there has been a utility power failure, or an internal failure of the AGSVL suppression components. If the internal suppression components fail, a short circuit will result. The short circuit will open the overcurrent device on the power supply, removing power to the AGSVL. Whenever power is removed from the AGSVL, the green LED will not illuminate.

6.0 Maintenance

Preventive Maintenance (Inspection and Cleaning) - Periodic system inspections, cleaning, and connection checks are recommended to ensure reliable system performance. There is no defined schedule for preventive maintenance, as conditions will vary from installation to installation.

Corrective Maintenance (Repair or Replacement) - AGSVL products are designed to provide years of continuous service. However, even the most reliable equipment may fail. In the unlikely case that the LED monitor is not illuminated, check the overcurrent protection on the power supply. Replace or reset the overcurrent protection. If a problem still exists, contact Cutler-Hammer's warranty Department at:

1-403-717-2000, opt. #5

7.0 Warranty

Standard - Cutler-Hammer warrants its products for a period of five years from the date of delivery to the purchaser to be free from defects in both workmanship and materials. Cutler-Hammer assumes no risk or liability for results of the use of the products purchased from it, including but without limiting the generality of the foregoing: (1) The use in combination with any electrical or electronic components, circuits, systems, assemblies or any other materials or substances. (2) Unsuitability of any product for use in any circuit or assembly. Purchaser's rights under the warranty shall consist solely of requiring Cutler-Hammer to repair, or at Cutler-Hammer's sole discretion, replace, free of charge, F.O.B factory, any defective items received at said factory within said term determined by Cutler-Hammer to be defective. The giving of or failure to give any advice or recommendations by Cutler-Hammer shall not constitute any warranty by or impose any liability upon Cutler-Hammer.

The foregoing constitutes the sole and exclusive remedy of the purchaser and the exclusive liability of Cutler-Hammer AND IS IN LIEU OF ANY AND ALL OTHER WARRANTIES EXPRESSED, IMPLIED OR STATUTORY AS TO THE MERCHANTABILITY, FITNESS FOR PURPOSE SOLD, DESCRIPTION, QUALITY, PRODUCTIVENESS OR ANY OTHER MATTER. In no event shall Cutler-Hammer be liable for special or consequential damages or for delay in performance of the warranty.

This warranty does not apply if the unit has been misused, abused, altered, tampered with, or used on current other than specified on the nameplate. At the end of the warranty period, Cutler-Hammer shall be under no further warranty obligation expressed or implied

The filter covered by this warranty certificate can only be repaired or replaced by the factory. To initiate a claim, contact Cutler-Hammer's Warranty Department at (403) 717-2000, (opt. #5) to receive Return Product Number (R.P.N.). The R.P.N. must be visible on the outside of the shipping carton to be accepted by Cutler-Hammer's Receiving department.

It should then be forwarded, **freight, brokerage and Duty Prepaid** to:

Cutler-Hammer

**#10, 2256 29th Street N.E.
Calgary, AB., Canada, T1Y 7G4**

Include a detailed description of the fault, your name, address and telephone number. Repair or replacement will be returned to customer collect. If Cutler-Hammer finds the return is a result of a manufacturer's default, the unit will be returned prepaid.