

Port Expander

Model 232PE

Document No. 232PE3095

This product

**Designed and Manufactured
In Ottawa, Illinois
USA**

of domestic and imported parts by

B&B Electronics Mfg. Co. Inc.

707 Dayton Road -- P.O. Box 1040 -- Ottawa, IL 61350
PH (815) 433-5100 -- FAX (815) 434-7094

Internet:

<http://www.bb-elec.com>
sales@bb-elec.com
techsupt@bb.elec.com

© 1993 B&B Electronics -- June 1993

TABLE OF CONTENTS

Chapter 1: HARDWARE	1
Introduction	1
Checklist	2
Port Expansion Bus.....	2
Setting The Address.....	2
Connecting To The Bus.....	4
Port Configuration	5
RS-232 Configuration.....	5
RS-422/485 Option	6
RS-422 Mode.....	7
RS-485 Mode.....	8
Specifications.....	10
Appendix A: Cable Charts	A-1
Chart 1. IBM PC DB25 Connector to Master Port	A-2
Chart 2. IBM PC DB9 Connector to Master Port	A-2
Chart 3. Modem DB25 Connector to Master Port.....	A-3
Chart 4. DCE Device w/DB25 Connector to Ports A - D (DTE).....	A-3
Chart 5. IBM PC DB25 Connector to Ports A - D (DTE)..	A-4
Chart 6. IBM PC DB9 Connector to Ports A - D (DTE)....	A-4
Chart 7. IBM PC DB25 Connector to Ports A - D (DTE)..	A-5
Chart 8. IBM PC DB9 Connector to Ports A - D(DTE).....	A-5
Chart 9. RS-422/485 4-Wire Device to Port (A - D) Configured as an RS-422 /485 Port.....	A-6
Chart 10. RS-422/485 2-Wire Device to Port (A - D) Configured as an RS-422 /485 Port.....	A-6

Chapter 1: HARDWARE

Introduction

The Port Expander (232PE) adds four asynchronous serial data ports to the Expandable Smart Switch (232XSS). Up to fifteen Port Expanders can be connected to a single 232XSS via the Port Expansion Bus. Refer to Figure 1. This expands the eight ports on the 232XSS to a maximum of sixty-eight ports. RS-232 ports are standard on the 232PE, RS-422/485 ports are optional. RS-232 ports are configured as DTE ports and support signals TD, RD, RTS, CTS, DTR, and DSR or CD. Ports configured as RS-422/485 support only signals TD and RD.

There are five red indicator LED's on the front of the 232XSS. Four LED's represent ports "A" through "D" and indicate the selected port. The fifth LED is the "Power On" indicator. Refer to Figure 7. There are five connectors located on the back of the 232PE, a twenty pin expansion bus connector, four DB-25P male connectors for ports "A" through "D", and an eleven inch bus expansion ribbon cable. Refer to Figure 8.

In order to select a port on a Port Expander, each expander is assigned its own unique address. A four position DIP switch in the Port Expander is used to set this address. An address field is part of the port selection control string that is received by the master port of the Expandable Smart Switch. Refer to the Expandable Smart Switch manual for more details regarding port selection. There is no delay through the Port Expander and the data is not buffered.

Figure 1. Simplified Functional Diagram

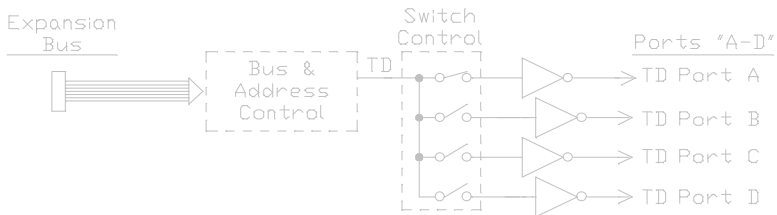

This diagram illustrates only the transmit data (TD) signal.

Checklist

The following equipment should be in the shipping carton:

1. Port Expander
2. Instruction Manual

If any of the items above are damaged or missing contact the shipper immediately.

Port Expansion Bus

The number of serial ports on the Expandable Smart Switch can easily be expanded to a maximum of sixty-eight ports by daisy chaining Port Expander units on the 232XSS's expansion bus. A maximum of fifteen Port Expander units can be added to a 232XSS. Each Port Expander unit (232PE) adds four additional serial ports. The Port Expansion Bus connects each port to the electronic switch control circuit in the 232XSS.

Setting The Address

Port Expanders must be assigned their own unique address. Located inside the 232PE is a four position DIP switch (SW1) which sets the unit's address. Refer to Figure 2. Select an unused address from "1" to "15" using Table 1.

CAUTION: Always power down the 232PE before removing its cover.

Do not select an address that is used by another Port Expander, data collisions can occur and data will be lost!

Figure 2. Printed Circuit Board Outline

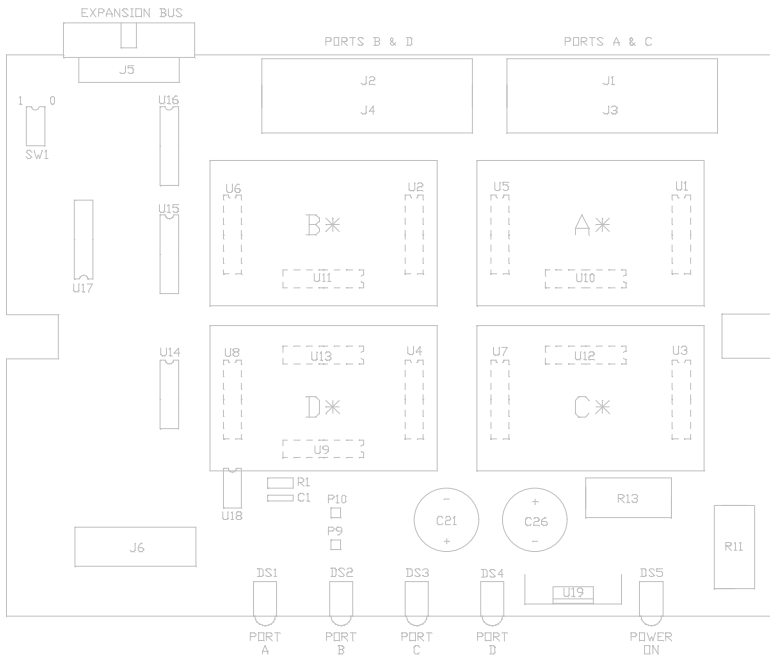

* PC board for optional RS-422/485 port.

Table 1. Address Switch

DIP Switch 1				Address
1	2	3	4	
0	0	0	0	Invalid
1	0	0	0	1
0	1	0	0	2
1	1	0	0	3
0	0	1	0	4
1	0	1	0	5
0	1	1	0	6
1	1	1	0	7
0	0	0	1	8
1	0	0	1	9
0	1	0	1	10
1	1	0	1	11
0	0	1	1	12
1	0	1	1	13
0	1	1	1	14
1	1	1	1	15*

1 = OFF 0 = ON

* = FACTORY DEFAULT

Connecting To The Bus

Connecting the Port Expander to the Expandable Smart Switch bus is a simple task. On the rear panel of the Port Expander is an expansion bus cable, refer to Figure 3. This cable simply plugs into the bus expansion connector located on the back of the last unit connected to the Expandable Smart Switch bus.

Figure 3. Bus Connection Diagram

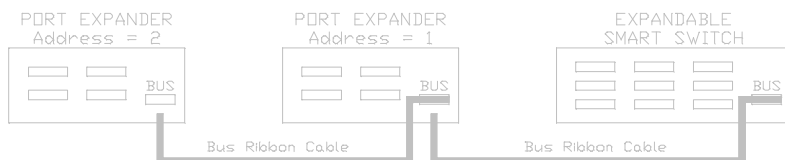

Port Configuration

The 232PE has four selectable ports labeled "A" through "D". Refer to Figure 8. Any of the ports can be manufactured to meet either RS-232 or RS-422/485 electrical characteristics.

RS-232 Configuration

RS-232 ports will be wired as DTE ports. Refer to Table 2 for pin out, signal name, and signal direction information. Also, refer to Figure 4 for a simplified schematic showing the relationship between the master port of the 232XSS and any RS-232 port of the 232PE. Refer to Appendix B for cable charts.

Table 2. RS-232 DTE PORTS A - D

Pin #	Signal	Description	RS-232 Signal Direction of DTE Ports A through D
2	TD	Transmit Data	Output
3	RD	Receive Data	Input
4	RTS	Request to Send	Output
5	CTS	Clear to Send	Input
6*	DSR	Data Set Ready	Input
7	SG	Signal Ground	<----->
8*	CD	Carrier Detect	Input
20	DTR	Data Term Ready	Output

* Pins 6 & 8 are tied together inside the 232PE and share the same input, refer to Figure 4.

Figure 4. Simplified RS-232 Schematic

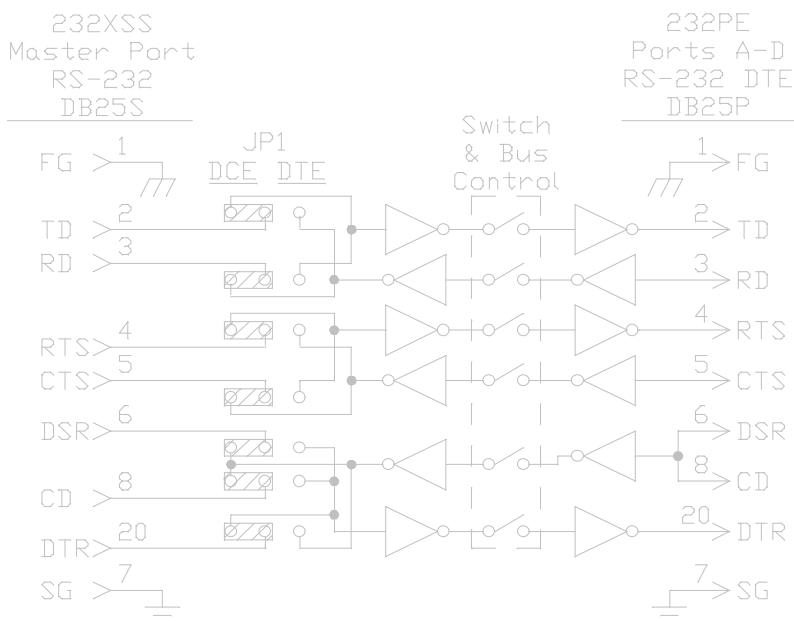

RS-422/485 Option

The RS-232 transmit and receive data signals on the master port of the 232XSS will be converted to balanced full-duplex RS-422 or half-duplex RS-485 signals with this option.

Table 3. RS-422/485 PORTS A - D

Pin #	Signal	Description	RS-422/485 Signal Direction of Ports A - D
2	TD(A)	Transmit Data (A)	Output
14	TD(B)	Transmit Data (B)	Output
7	SG	Signal Ground	<----->
3	RD(A)	Receive Data (A)	Input
16	RD(B)	Receive Data (B)	Input

Figure 5. Simplified RS-422/485 Schematic

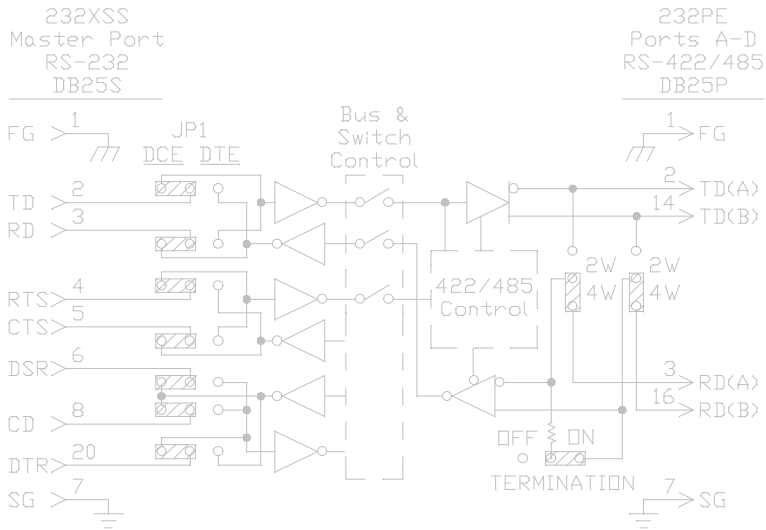

When a port has this option, an additional printed circuit board will be mounted to the main board. Use Figure 2 to locate its position. Refer to Table 3 for pin out, signal name, and signal direction information. Also, refer to Figure 5 for a simplified schematic showing the relationship between the master port and a port configured with the RS-422/485 option.

NOTE: This option only supports transmit and receive data signals (TD & RD) from the master port.

Refer to Appendix B for cable charts.

RS-422 Mode

To configure the port for RS-422 four-wire mode, five jumpers must be set. Jumper JP1 must be placed in the "SD" position. Both JP2 jumpers must be placed in the four-wire "4W" position. Jumper JP3 must be placed in the "ON" position. Jumper JP4 should be placed in the "ON" position. Refer to Figure 6 for these jumper locations.

The EIA RS-422 Specification labels data lines with "A" and "B" designators. Some RS-422 equipment uses a "+" and "-" designator. In almost all cases, the "A" line is the equivalent of the "-" line and the "B" line is the equivalent of the "+" line.

Figure 6. P.C. Board for Optional RS-422/485 Port

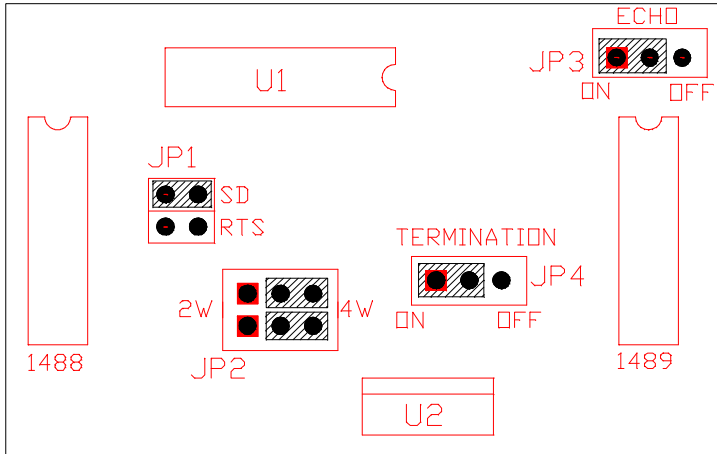

RS-485 Mode

There are two methods that can be used to control the RS-422/485 driver: handshake control (RTS) and send data (SD) control. These methods are jumper selectable (JP1 "SD" & "RTS").

Handshake control requires that the software use a handshake signal to enable/disable the RS-485 driver. The handshake signal RTS (pin 4) is used when the master port is configured as a DCE port and CTS (pin 5) is used when the master port is configured as a DTE port.

SD control automatically enables the RS-485 driver by sensing the leading edge of the first character transmitted from the device connected to the master port. After the last character is transmitted the send data timer circuit waits one character time (1 millisecond at 9600 baud) before disabling the RS-485 driver.

There are two components on the main printed circuit board, a resistor (R1) and a capacitor (C1), that are part of the send data control circuit. These components are factory selected for 9600 baud, which allows the send data control to operate at 9600 baud or higher. With these two components the RS-485 driver will be disabled approximately 1 millisecond after the last character has

been sent. To change to a baud rate lower than 9600 baud, or to configure the send data control to match a specific baud rate, change R1 and C1 to the value specified in Table 4. Use Figure 2 to locate R1 and C1. Note that these timing components are not used when the handshake control method is selected.

Table 4. Component Values For Send Data Timing

Baud Rate	Time (ms)	Resistor Value R1 (ohms)	Capacitor Value C1(microfarads)
300	33.3	330K	.1
600	16.6	160K	.1
1200	8.33	820K	.01
2400	4.16	430K	.01
4800	2.08	200K	.01
9600	1.04	100K	.01
19.2K	0.520	56K	.01
38.4K	0.260	27K	.01
57.6K	0.176	16K	.01
115.2K	0.0868	8.2K	.01

The ECHO jumper (JP3) selects how the RS-485 receiver is controlled. It can be set to ECHO ON which constantly enables the receiver (RS-422, 4-wire mode) or to ECHO OFF which allows the receiver to be automatically enabled when the RS-485 driver is disabled (2-wire mode). When in the ECHO OFF position and in 2-wire mode, the data being sent from the RS-232 device connected to the master port will not be echoed back to the master port.

To configure a port for RS-485 two-wire mode, five jumpers must be set. Jumper JP1 must be placed either the "SD" or the "RTS" position, depending on how you control the RS-485 driver. Both JP2 jumpers must be placed in the two-wire "2W" position. Jumper JP3 must be placed in the "OFF" position. Jumper JP4 should be placed in the "ON" position if this port is located at either end of the multi-drop line, otherwise it should be in the "OFF" position. Refer to Figure 6 for these jumper locations.

Specifications

Model: 232PE

Size: 8"w x 6.3"d x 2.7"h

Power: 120Vac 60hz 16w

Figure 7. Front View

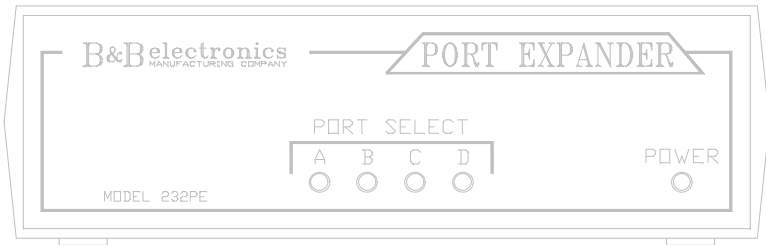
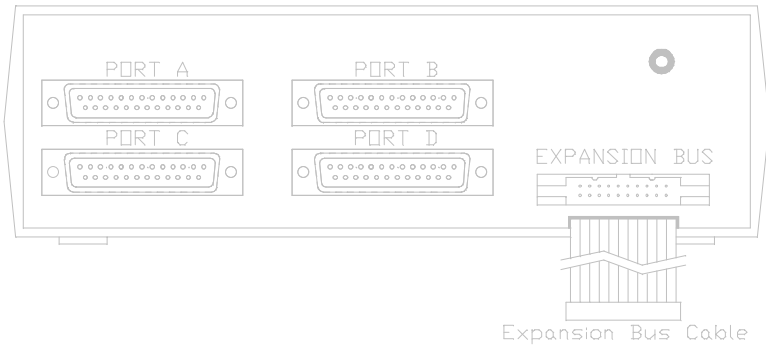

Figure 8. Rear View



Appendix A: Cable Charts

These charts indicate some common cable wiring based on the DCE/DTE configuration of the 232XSS Master Port. Refer to the Port Configuration section of the 232XSS manual for information on Master Port configurations.

Chart 1. IBM PC DB25 Connector to Master Port

Master Port configured as a DCE port.

IBM PC Serial Port DB25 Connector	Signal Direction	232XSS Master Port (DCE) DB25 Connector
2	----->	2
3	<-----	3
4	----->	4
5	<-----	5
6	<-----	6*
7	<----->	7
8	<-----	8*
20	----->	20

* Pins 6 & 8 are tied together inside the 232XSS and share the same output.

Chart 2. IBM PC DB9 Connector to Master Port

Master port configured as a DCE port.

IBM PC Serial Port DB9 Connector	Signal Direction	232XSS Master Port (DCE) DB25 Connector
1	<-----	8*
2	<-----	3
3	----->	2
4	----->	20
5	<----->	7
6	<-----	6*
7	----->	4
8	<-----	5

* Pins 6 & 8 are tied together inside the 232XSS and share the same output.

Chart 3. Modem DB25 Connector to Master Port

Master port configured as a DTE port.

Async Modem Serial Port DB25 Connector	Signal Direction	232XSS Master Port (DTE) DB25 Connector
2	<-----	2
3	----->	3
4	<-----	4
5	----->	5
7	<----->	7
8	----->	8*
20	<-----	20

* Pins 6 & 8 are tied together inside the 232XSS and share the same input.

NOTE: When using chart 3 above and connecting a DTE device to ports A - H of the smart switch, refer to Charts 7 and 8.

Chart 4. DCE Device w/DB25 Connector to Ports A - D (DTE)

Master port of 232PE configured as a DCE port.

DCE Device Serial Port DB25 Connector	Signal Direction	232PE Ports A - D (DTE) DB25 Connector
2	<-----	2
3	----->	3
4	<-----	4
5	----->	5
6	----->	6*
7	<----->	7
8	----->	8*
20	<-----	20

* Pins 6 & 8 are tied together inside the 232PE and share the same input.

Chart 5. IBM PC DB25 Connector to Ports A - D (DTE)

Master port of 232XSS configured as a DCE port.

IBM PC Serial Port DB25 Connector	Signal Direction	232PE Ports A - D (DTE) DB25 Connector
2	----->	3
3	<-----	2
4	----->	5
5	<-----	4
6	<-----	6*
7	<----->	7
8	<-----	8*
20	----->	20

* Pins are tied together inside the 232PE and share the same input.

Chart 6. IBM PC DB9 Connector to Ports A - D (DTE)

Master port of 232XSS configured as a DCE port.

IBM PC Serial Port DB9 Connector	Signal Direction	232PE Ports A - D (DTE) DB25 Connector
2	<-----	2
3	----->	3
4	----->	6*
5	<----->	7
6	<-----	20
7	----->	5
8	<-----	4

* Pins 6 & 8 are tied together inside the 232PE and share the same input.

Chart 7. IBM PC DB25 Connector to Ports A - D (DTE)

Master port of 232XSS configured as a DTE port with a modem connected (see Chart 3).

IBM PC Serial Port DB25 Connector	Signal Direction	232PE Ports A - D (DTE) DB25 Connector
2	----->	3
3	<-----	2
4	----->	5
5	<-----	4
6	<---- ---->	6*
7	<----->	7
8	<-----	20
20	----->	6*

* Pins 6 & 8 are tied together inside the 232PE and share the same input.

Chart 8. IBM PC DB9 Connector to Ports A - D(DTE)

Master port of 232XSS configured as a DTE port with a modem connected (see Chart 3).

IBM PC Serial Port DB9 Connector	Signal Direction	232PE Ports A - D (DTE) DB25 Connector
3	----->	3
2	<-----	2
7	----->	5
8	<-----	4
6	<---- ---->	6*
5	<----->	7
1	<-----	20
4	----->	6*

* Pins 6 & 8 are tied together inside the 232PE and share the same input.

Chart 9. RS-422/485 4-Wire Device to Port (A - D) Configured as an RS-422 /485 Port.

Master port of 232XSS configured as an RS-232 DCE port.

RS-422/485 4-Wire Device	Signal Direction	232PE Ports A - D DB25 Connector
TD (A)*	----->	3 - RD (A)
TD (B)*	----->	16 - RD (B)
Signal Ground	<----->	7 - SG
RD (A)*	<-----	2 - TD (A)
RD (B)*	<-----	14 - TD (B)

* If the device being connected uses "+" and "-" in place of "B" and "A", the "+" replaces the "B" and the "-" replaces the "A".

NOTE: Make sure the port's set up jumpers are in the proper position for four-wire communications.

Chart 10. RS-422/485 2-Wire Device to Port (A - D) Configured as an RS-422/485 Port.

Master port of 232XSS configured as an RS-232 DCE port.

RS-422/485 2-Wire Device	Signal Direction	232PE Ports A - D DB25 Connector
Data (A)*	<----->	2 - TD (A)
Data (B)*	<----->	14 -TD (B)
Signal Ground	<----->	7 - SG

* If the device being connected uses "+" and "-" in place of "B" and "A", the "+" replaces the "B" and the "-" replaces the "A".

NOTE: Make sure the port's set up jumpers are in the proper position for two-wire communications.

FEDERAL COMMUNICATIONS COMMISSION RADIO FREQUENCY INTERFACE STATEMENT

Class A Equipment

This equipment has been tested and found to comply with the limits for Class A digital device, pursuant to Part 15 of the FCC Rules. These limits are designed to provide reasonable protection against harmful interference when the equipment is operated in a commercial environment. This equipment generates, uses, and can radiate radio frequency energy and, if not installed and used in accordance with the instructions, may cause harmful interference to radio communications. Operation of this equipment in a residential area is likely to cause harmful interference, in which case the user will be required to correct the interference at personal expense.