

RS-485 Data Acquisition Module

Model 485SDA10

Document No. 485SDA103798

This product

Designed and Manufactured

In Ottawa, Illinois

USA

of domestic and imported parts by

B&B Electronics Mfg. Co. Inc.

707 Dayton Rd. -- P.O. Box 1040 -- Ottawa, IL 61350

PH (815) 433-5100 -- FAX (815) 434-7094

Internet:

<http://www.bb-elec.com>

sales@bb-elec.com

support@bb.elec.com

© 1995 B&B Electronics -- Revised September 1998

Table of Contents

Chapter 1- Introduction	1
485SDA10 Features	1
Packing List.....	2
Software Installation	2
DOS.....	2
Windows 3.11	3
Windows 9x and Windows NT.....	3
Uninstall.....	3
Windows 3.11	3
Windows 9x & Windows NT	3
Getting Started	3
485SDA10 Specifications	5
Analog to Digital Converter.....	5
5 Volt Reference.....	5
Digital Inputs	5
Digital Outputs	5
Power Supply.....	5
Communications.....	5
Factory Default Settings	5
Chapter 2 - Connections.....	6
A/D Connections.....	6
A/D Inputs #0-10.....	6
A/D Ref Input +	6
A/D Ref Input -.....	7
Analog Ground.....	7
Typical Connections	7
Digital I/O Connections.....	8
Digital Inputs #0-2.....	8
Digital Outputs #0-2.....	8
Digital Ground.....	9
Typical Connections	9
Serial Port Connections.....	10
Power Supply Connections.....	11
Chapter 3 - Commands.....	12
Syntax	13
Reading A/D Channels Command.....	13
Reading Digital I/O Command.....	15
Set Digital Output Command.....	16
Set Module Address Command.....	16
Set Power-up States Command	17

Set Turn-around Delay Command	17
Read Module Configuration Command	17
Chapter 4 - A/D	19
Sampling Rate	19
A/D Input Range	19
Reference Inputs	19
Data Range	20
Converting Data.....	20
Chapter 5 - Software	22
Read A/D Command	22
Read Digital I/O Command.....	23
Set Digital Output States	24
Set Module Address	25
Set Power-up States Command	26
Set Turn-around Delay	27
Read Module Configuration	28
Appendix A: Adding Data Field Confirmation....	A-1
Appendix B: Analog Input Impedance.....	B-1
Appendix C: Decimal to HEX to ASCII Table	C-1

Figures

FIGURE 1.1 - 485SDA10 UNIT	1
FIGURE 1.2 - GENERAL BLOCK DIAGRAM	2
FIGURE 1.3 - A/D WITH VARIABLE RESISTOR	4
FIGURE 2.1 - TYPICAL 0-5V A/D CONNECTION	7
FIGURE 2.2 - TYPICAL DIGITAL I/O CONNECTIONS	9
FIGURE 4.1 - A/D CONVERTER DATA RANGE.....	20
FIGURE B-1 - EQUIVALENT INPUT CIRCUIT INCL/DRIVING SOURCEB-3	

Tables

TABLE 2.1 - 485SDA10 I/O PORT PINOUT	8
TABLE 2.2 - RS-485 TERMINAL BLOCK CONNECTIONS	10
TABLE 3.1 - 485SDA10 COMMANDS	12
TABLE 3.2 - EQUIVALENT VALUES	13
TABLE 3.3 - READ A/D RESPONSE.....	14
TABLE 3.4 - READ DIGITAL I/O RESPONSE FOR OUTPUTS.....	15
TABLE 3.5 - READ DIGITAL I/O RESPONSE FOR INPUTS.....	15
TABLE 3.6 - SET DIGITAL OUTPUT DATA BYTE VALUES	16

TABLE 5.1 - DIGITAL I/O MASK VALUES..... 24
TABLE A-1 EXTENDED COMMANDS..... A-2
TABLE C-1: DECIMAL TO HEX TO ASCII TABLE..... C-1

Chapter 1- Introduction

485SDA10 Features

The 485SDA10 is a general purpose control module which operates through an RS-485 interface. The 485SDA10 offers 11 channels of 10-bit A/D (analog to digital), 3 digital inputs and 3 digital outputs. With these features, the module can be used to sense a variety of external conditions and to control a variety of devices.

The 11 A/D channels allow you to measure voltages from 0 to 5 Volts. The 3 digital inputs and 3 digital outputs are CMOS/TTL compatible. The A/D and digital I/O lines are available through a DB-25S (female) connector.

The 485SDA10 connects to the host computer's RS-485 or RS-422 serial port using terminal blocks. The address and turn-around delays are software programmable to allow use of multiple devices or connection to existing systems. The unit automatically detects baud rates from 1200 to 9600. A data format of 8 data bits, 1 stop bit and no parity is used.

Configuration parameters are stored in non-volatile memory. The configuration parameters consist of the module address, communication turn-around delay, and digital output power-up states.

Figure 1.1 - 485SDA10 Unit

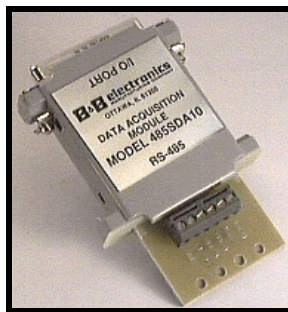

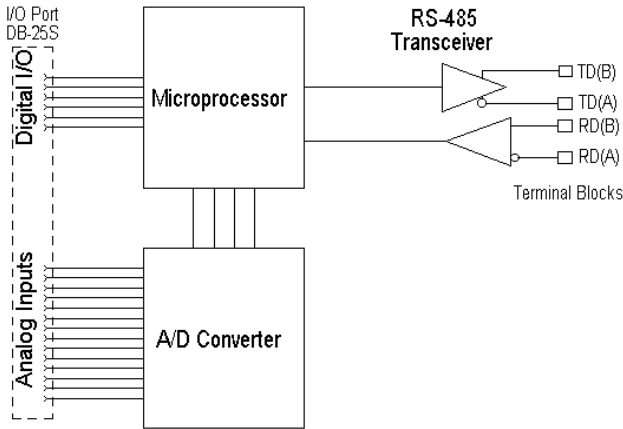

Figure 1.2 - General Block Diagram

Packing List

Examine the shipping carton and contents for physical damage. The following items should be in the shipping carton:

- 485SDA10 unit
- One 485SDA10 3.5" disk
- This instruction manual
- RS-485/422 Application Note

If any of these items are damaged or missing contact B&B Electronics immediately.

Software Installation

The 485SDA10 comes with several useful programs such as a data logging utility, a demonstration program, etc. The installation for the SDA Logger is different depending on the platform you install it to. Please use the one appropriate to your system.

DOS

1. Place the disk in drive A.
2. Type **A:** and press the **<ENTER>** key.
3. Type **INSTALL** and press the **<ENTER>** key.
4. Follow the instructions given by the program.

Windows 3.11

1. Insert SDA Logger installation disk in your floppy drive.
2. Click the File Manager button.
3. Select the floppy drive containing the SDA Logger installation disk.
4. Double click the Setup.exe icon when it appears.
5. Follow the installation instructions as prompted.

Windows 9x and Windows NT

1. Insert the SDA Logger installation disk in your floppy drive.
2. Click Start | Run.
3. Click the Browse button and choose the floppy drive containing the SDA Logger installation disk.
4. Double click the Setup.exe icon when it appears.
5. Click the OK button to run the Setup.exe program.
6. Follow the installation instructions as prompted.

Uninstall

Uninstall for the SDA Logger version is different for each Windows operating system. Below are the methods for uninstalling the SDA Logger.

Windows 3.11

1. Open the File Manager in the Control Panel.
2. Click the drive that SDA Logger was installed to.
3. Click the SDA16 directory.
4. Double click the UNWISE.EXE.
5. Follow the Uninstall Wizard.

Windows 9x & Windows NT

1. Open Start | Settings | Control Panel.
2. Open ADD/REMOVE PROGRAMS.
3. Click SDA LOGGER.
4. Click the Add/Remove button.
5. Follow the Uninstall Wizard.

Getting Started

This section will provide a quick example using the 485SDA10 and the demonstration program. If you experience any problems, refer to Chapter 2 for more precise information on connections. The demo program continually reads the A/D inputs and the digital I/O. The states of the digital outputs can be toggled using F2, F3, and F4. The serial port is configured for 9600 baud, 8 data bits, no parity, and 1 stop bit. The program supports standard addresses and IRQ's for COM1 and COM2.

- Connect a 0 to 5V DC analog device to A/D input #0, or you can connect a variable resistor as shown in Figure 1.3. The

variable resistor must be greater than 1k Ohms to limit the output current to 5mA.

- Connect A/D Ref Input+ to +5V DC.
- Connect A/D Ref Input- to analog ground (See Figure 1.3).
- Connect the 485SDA10 to an RS-422 or 4-wire RS-485 serial port.

Once your connections have been made, run the demo program. Any change in A/D or digital lines on the 485SDA10 will automatically be displayed on the screen.

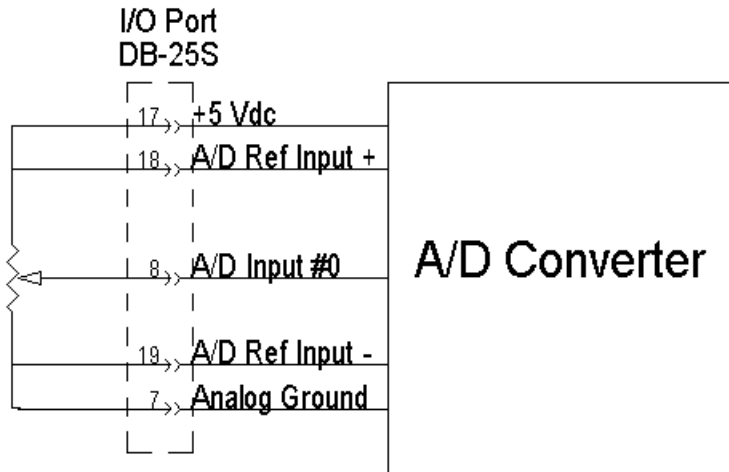

Figure 1.3 - A/D with Variable Resistor

485SDA10 Specifications

Analog to Digital Converter

Resolution:	10 bit
Channels:	11
Reference Range:	5.0V DC max. (4.888 mV per bit) 2.5V DC min. (2.444 mV per bit)
A/D Ref. Input -	0V DC to 2.5V DC
A/D Ref. Input +	2.5V DC to 5.0V DC
Input Voltage Range:	-0.3V DC to 5.3V DC
Total Unadjusted Error:	+/- 1 LSB max.

A/D input channels must be driven from a source impedance less than 1k Ω .

5 Volt Reference

Output Voltage:	4.975 to 5.025V DC (5.0V DC typ.)
Accuracy:	+/- 0.5 %
Output Current:	5mA max.

Digital Inputs

Channels:	3
Voltage Range:	-30V DC to 30V DC
Low Voltage:	-30V DC to 1.0V DC
High Voltage:	2.0V DC to 30V DC
Leakage Current:	1 μ A max.

Digital Outputs

Channels:	3
Low Voltage:	0.6V DC @ 8.7mA
High Voltage:	4.3V DC @ -5.4mA

Power Supply

Input Voltage:	7V DC to 18V DC @ 30mA (Doesn't include the power consumption of external devices.)
----------------	--

Communications

Standard:	RS-422/485
Addresses:	256
Turn-around Delay:	Software programmable from 0 to 255 character transmission times. (1 char. trans. time @ 9600 baud = 1ms)
Baud Rate:	1200 to 9600 (automatic detection)
Format:	8 data bits, 1 stop bit, no parity
Connector:	DB-25S (female)

Factory Default Settings

Address:	ASCII "0" (48 decimal or 30h)
Turn-around Delay:	1
Power-up States:	0

Chapter 2 - Connections

This chapter will cover the connections required for the 485SDA10. There are four sets of connections:

- A/D converter
- Digital I/O
- Serial port
- Power supply

Do not make any connections to the 485SDA10 until you have read this chapter.

CAUTION: When making electrical connections it is important to power down the devices being connected. If this is not possible, precautions must be taken to ensure electrical specifications are not exceeded.

NOTE: If you do not intend to use a section (A/D or I/O), it is still important to read each one.

A/D Connections

The A/D connections are made on the I/O port, which is a DB-25S (female) connector. Table 2.1 shows the pinout of the I/O port. The next sections explain the functions and connections for the various analog signals.

A/D Inputs #0-10

These are the analog input channels. The analog data that is read from the 485SDA10 is related to the voltage on these pins. Connect your devices to the analog input channels. Voltages on these inputs must remain between 0 and 5.0V DC. Connect unused A/D inputs to analog ground.

A/D Ref Input +

The voltage connected to this pin determines the upper end of the input voltage range. For proper operation, this pin must be connected to a DC voltage between +2.5 and +5.0 Volts. The 485SDA10 provides a 5.0V +/-0.5% reference on pin 17. The 5V reference can be used if you require a 0 to 5V DC input range. If your application requires a better reference voltage or a different input range, you must supply the appropriate reference to the A/D Ref Input+ pin. This voltage **must be at least 2.5V greater than A/D Ref Input-**. Bypassing the A/D Ref Input+ pin with 0.01 μ F ceramic and 10 μ F tantalum capacitors to analog ground will decrease noise levels.

A/D Ref Input -

The voltage connected to this pin determines the low end of the input voltage range. For proper operation, this pin must be connected to a DC voltage between 0 and +2.5 Volts. Typically, this is connected to your device's ground and analog ground (0V).

Analog Ground

This pin should be connected to your analog device's ground. If ground (0V) is the low end of your input voltage range, A/D Ref Input- should be connected to this pin. To minimize noise, **do not connect** analog ground and digital ground together. Connect unused A/D inputs to analog ground.

Typical Connections

Figure 2.1 shows the typical connections of the 485SDA10 for a 0 to 5V DC input range.

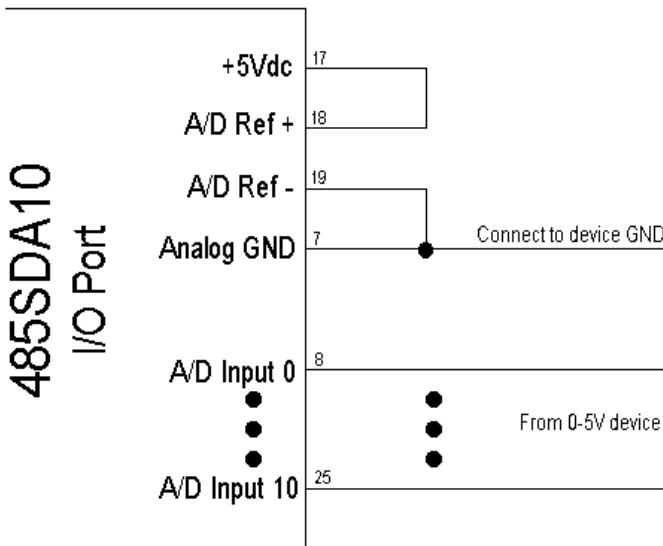

Figure 2.1 - Typical 0-5V A/D Connection

Digital I/O Connections

The digital I/O connections are made on the I/O port, which is a DB-25S (female) connector. Table 2.1 shows the pinout of the I/O port. The next sections explain the functions and connections for the various digital signals.

Table 2.1 - 485SDA10 I/O Port Pinout

DB-25S Pin #	Function	DB-25S Pin #	Function
1	GND	14	Digital Output #0
2	+12V DC Output*	15	Digital Output #1
3	Digital Input #0	16	Digital Output #2
4	Digital Input #1	17	+5V DC Output
5	Digital Input #2	18	A/D Ref. Input +
6	Digital GND	19	A/D Ref. Input -
7	Analog GND	20	No connection
8	A/D Input #0	21	A/D Input #6
9	A/D Input #1	22	A/D Input #7
10	A/D Input #2	23	A/D Input #8
11	A/D Input #3	24	A/D Input #9
12	A/D Input #4	25	A/D Input #10
13	A/D Input #5		

*Actual output is equal to power supply input minus 0.7V DC

Digital Inputs #0-2

The digital input lines are CMOS/TTL compatible and can handle voltages from -30V DC to +30V DC. If a digital input is from -30V DC to 1.0V DC, the state will be read as a "0" (LOW). If a digital input is from 2.0V DC to 30V DC, the state will be read as a "1" (HIGH). Connect unused digital inputs to digital ground.

Digital Outputs #0-2

The digital output lines are CMOS/TTL compatible. A digital output that is set to a "0" (LOW) will output a voltage from 0 to 0.6V DC. A digital output that is set to a "1" (HIGH) will output a voltage from 4.3V DC to 5.0V DC. Refer to Chapter 1, Specifications, for more information. Unused digital output lines should be left open.

Digital Ground

Connect the digital ground pin to your digital device's ground. To minimize noise, **do not connect** analog ground and digital ground together. Connect unused digital inputs to digital ground.

Typical Connections

Figure 2.2 shows the typical connections of the 485SDA10 for the digital I/O lines.

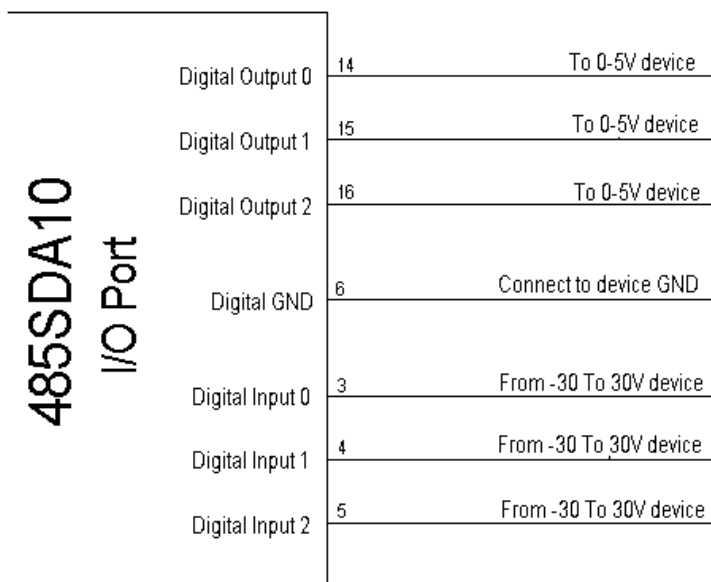

Figure 2.2 - Typical Digital I/O Connections

Serial Port Connections

To communicate with the 485SDA10 module, it must be connected to an RS-422/RS-485 serial port. The 485SDA10 works with 2-wire or 4-wire RS-485. The unit automatically detects baud rates from 1200 to 9600. A data format of 8 data bits, 1 stop bit and no parity is used. Connections are made using terminal blocks. Table 2.2 shows the terminal blocks and their functions.

Table 2.2 - RS-485 Terminal Block Connections

TB Label	Signal	485SDA10 Function	Notes
TD(A)	Transmit Data (A)	Output	Connection is required. [Loop to RD(A) for 2-wire hookup]
TD(B)	Transmit Data (B)	Output	Connection is required. [Loop to RD(B) for 2-wire hookup]
RD(A)	Receive Data (A)	Input	Connection is required. [Loop to RD(A) for 2-wire hookup]
RD(B)	Receive Data (B)	Input	Connection is required. [Loop to RD(B) for 2-wire hookup]
GND	Ground	-	Connection for Signal GND and Power Supply GND.
+12V	+12 V DC Power	Input	Connection is required.

A typical 2-wire RS-485 connection is shown in Figure 2.3 and a typical RS-422 (or RS-485) 4-wire is shown in Figure 2.4.

NOTE: The 485SDA10 labels the data lines with “A” and “B” designators (per EIA RS-485 Specification). However, some RS-485 equipment used “+” and “-” as designators. In most cases the “A” line is the equivalent of the “-” line and the “B” line is the equivalent of the “+” line. With an RS-485/422 system there are other factors that require consideration, such as termination and turn-around delay. For more information refer to the RS-485/422 Application Note (included in packing).

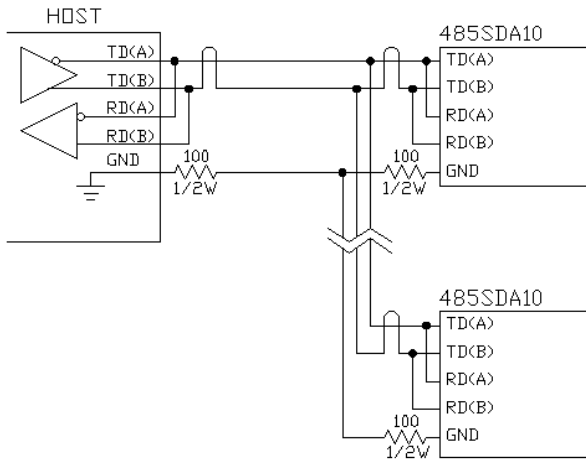

Figure 2.3 - Typical RS-485 2-wire Connection

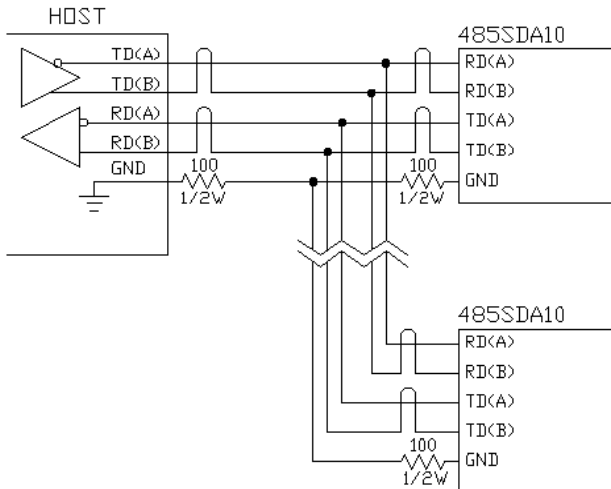

Figure 2.4 - Typical RS-422 Connection

Power Supply Connections

The 485SDA10 requires 7 to 18 V DC at 30mA. Remember that the 30mA requirement doesn't include the power consumption of any external devices. Therefore, any current sourced with the digital outputs must be added to this value.

Chapter 3 - Commands

There are only three commands required to control the 485SDA10:

- Read A/D command
- Read digital I/O command
- Set output states command

There are four commands used to configure the module:

- Set power-up states command
- Set turn-around delay command
- Set module address command
- Read module configuration command

The command string consists of four bytes. Some commands require an additional data byte. For information on adding data field confirmation to the data fields refer to Appendix A. See Table 3.1.

Table 3.1 - 485SDA10 Commands

Function	Command	Response
Read A/D Channels	!{addr}RA{#}	{ch#msb}{ch#lsb} {ch(#-1)msb}... {ch0msb}{ch0lsb}
Read Digital I/O	!{addr}RD	{I/O states}
Set Output States	!{addr}SO{#}	no response
Set Module Address	!{addr}SA{new addr}	no response
Set Power-up States	!{addr}SS{#}	no response
Set Turn-around Delay	!{addr}SC{#}	no response
Read Configuration	!{addr}RC	{addr}{powerup states}{turn-around delay}

NOTE: Each {...} represents one byte.

Before going into the specifics of each command, it is important to understand that a byte has a value from 0 to 255 and can be represented in decimal (0 to 255), hexadecimal (00 to FF), or by an ASCII character. The commands in Table 3.1 are shown in ASCII, for example:

<u>ASCII</u>	<u>Hex</u>	<u>Decimal</u>
!ORD	<21><30><52><44>	(33)(48)(82)(68)

The Read A/D channels command returns two bytes for each channel read. The two bytes represent the most significant byte (MSB) and least significant byte (LSB) of the reading. The MSB is received first, followed by the LSB. This command requires a data byte. The data byte is used to specify the number of the highest channel to be read. All channels less than this channel will be read as well. For example, if the data byte has a value of 6, then channels 0 to 6 will be read. The highest channel is read first.

Command Syntax

!{addr}RA{#}

Where “{#}” is a byte that specifies the number of the highest channel to be read. See Table 3.3

Response Syntax

{ch(#)MSB}{ch(#)LSB}{ch(#-1)MSB}...{ch0MSB}{ch0LSB}

The most significant byte of the channel specified is received first. The least significant byte and the lower channels will follow in descending order. “{chxMSB}” and “{chxLSB}” represent the most and least significant bytes of the A/D conversion result.

Table 3.3 - Read A/D Response

# of Channels Specified			Response	
decimal	Hex	ASCII	Channels Returned (order of response)	Bytes Returned
0	0	NUL	Channel 0	2
1	1	SOH	Channels 1,0	4
2	2	STX	Channels 2,1,0	6
3	3	ETX	Channels 3,2,...,0	8
4	4	EOT	Channels 4,3,...,0	10
5	5	ENQ	Channels 5,4,...,0	12
6	6	ACK	Channels 6,5,...,0	14
7	7	BEL	Channels 7,6,...,0	16
8	8	BS	Channels 8,7,...,0	18
9	9	HT	Channels 9,8,...,0	20
10	A	LF	Channels 10,9,...,0	22

NOTE: There are three test channels that can be read: Ref+, Ref-, and Ref+/2. Specify 13 (0Dh) to read Ref+, 12 (0Ch) to read Ref-, and 11 (0Bh) to read Ref+/2.

Reading Digital I/O Command

The Read Digital I/O command returns a byte which represents the states of the 3 digital input and 3 digital output states. Bits 3-5 correspond to the states of digital inputs 0-2. Bits 0-2 correspond to the states of digital outputs 0-2. If a bit is a 0 then the digital state of that digital I/O is LOW. If a bit is a 1 then the digital state of the I/O is HIGH. Refer to Table 3.4 and 3.5.

Command Syntax

!{addr}RD

Unit Response

{states}

Where **{states}** is a byte in which Bits 0-2 corresponds to the current states of Digital Outputs 0-2 and Bits 3-5 corresponds to the current states of Digital Inputs 0-2.

Table 3.4 - Read Digital I/O Response for Outputs

Response Byte			Digital Outputs		
Bit 2	Bit 1	Bit 0	#2	#1	#0
0	0	0	LOW	LOW	LOW
0	0	1	LOW	LOW	HIGH
0	1	0	LOW	HIGH	LOW
0	1	1	LOW	HIGH	HIGH
1	0	0	HIGH	LOW	LOW
1	0	1	HIGH	LOW	HIGH
1	1	0	HIGH	HIGH	LOW
1	1	1	HIGH	HIGH	HIGH

Table 3.5 - Read Digital I/O Response for Inputs

Response Byte			Digital Inputs		
Bit 5	Bit 4	Bit 3	#2	#1	#0
0	0	0	LOW	LOW	LOW
0	0	1	LOW	LOW	HIGH
0	1	0	LOW	HIGH	LOW
0	1	1	LOW	HIGH	HIGH
1	0	0	HIGH	LOW	LOW
1	0	1	HIGH	LOW	HIGH
1	1	0	HIGH	HIGH	LOW
1	1	1	HIGH	HIGH	HIGH

Set Digital Output Command

The Set Digital Output command is used to set the states of the 3 digital output lines. This command requires a data byte. The data byte is used to specify the output states. Bits 0-2 correspond to the states of digital outputs 0-2. If a bit is a 0 then the output will be set LOW. If a bit is a 1 then the output will be set HIGH. Refer to Table 3.6. NOTE: This command ignores Bits 3-7 of the data byte.

Command Syntax

!{addr}SO{states}

Where **{states}** is a byte in which Bits 0-2 correspond to the outputs states of Digital Outputs 0-2

Unit Response

no response

Table 3.6 - Set Digital Output Data Byte Values

Data Byte			Digital Outputs		
Bit 2	Bit 1	Bit 0	#2	#1	#0
0	0	0	LOW	LOW	LOW
0	0	1	LOW	LOW	HIGH
0	1	0	LOW	HIGH	LOW
0	1	1	LOW	HIGH	HIGH
1	0	0	HIGH	LOW	LOW
1	0	1	HIGH	LOW	HIGH
1	1	0	HIGH	HIGH	LOW
1	1	1	HIGH	HIGH	HIGH

Set Module Address Command

The Set Module Address command is used to change the address of a 485SDA10. This command requires a data byte. The data byte is used to specify the new address of the unit. The address of a module is stored in non-volatile memory.

Command Syntax

!{addr}SA{new address}

Response Syntax

no response

Where **{addr}** is the current address of the module and **{new address}** is a byte representing the new address.

Set Power-up States Command

The Set Power-up States command is used to set the states of the digital outputs at power-up. This command requires a data byte. The data byte is used to specify the power-up output states. Bits 0-2 correspond to the power-up states of digital outputs 0-2. If a bit is a 0 then the output will be set LOW at power-up. If a bit is a 1 then the output will be set HIGH at power-up. Refer to Table 3.6.

NOTE: This command ignores bits 3-7 of the data byte.

Command Syntax

!{addr}SS{states}

Response Syntax

no response

Where **{states}** is a byte in which Bits 0-2 correspond to the power-up states of Digital Outputs 0-2

Set Turn-around Delay Command

The Set Turn-around Delay command sets the amount of time the 485SDA10 waits to respond after executing a command. This delay is necessary when two RS-485 transmitters are sharing a pair of wires to ensure that two transmitters are not enabled at the same time. Refer to B&B Electronics' free RS-422/RS-485 Application Note for more information on RS-422/485. The turn-around delay is stored in non-volatile memory. This command requires a data byte. The data byte is used to specify the turn-around delay. One unit of turn-around delay is equal to the transmission time of one character. The transmission time can be computed as follows:

$$\text{time} = (1 / \text{baud rate}) * 10$$

Command Syntax

!{addr}SC{delay}

Response Syntax

no response

Where **{delay}** is a byte used to specify the turn-around delay.

Read Module Configuration Command

The Read Module Configuration command reads the 485SDA10's address, power-up states, and turn-around delay (in that order).

Command Syntax

!{addr}RC

Response Syntax

{address}{states}{delay}

Where **{address}** is a byte representing the module's current address, **{states}** is a byte representing the module's power-up states, and **{delay}** is a byte representing the module's turn-around delay.

Chapter 4 - A/D

This chapter will deal with manipulating an A/D reading and cover some of the aspects that were not explained in the A/D Connections chapter.

Sampling Rate

The A/D converter has a conversion time of around 20 microseconds, however the sampling rate is limited by the serial communications. The maximum sampling rate for a single channel is around 120 samples per second (9600 baud). This rate drops to 25 samples per second when sampling all of the channels. When reading an A/D input, the 485SDA10 takes four readings and returns the average (0.5 and greater are rounded up) of these readings. This averaging filters out noise.

A/D Input Range

The A/D input range on the 485SDA10 is from 0 to +5V DC. If it is possible for your device to output a voltage that doesn't fall in this range, steps must be taken to ensure that the voltage remains between 0 and +5V DC. Voltages outside this range will damage the unit.

Reference Inputs

The A/D reference inputs set the top and bottom of the data range. A/D Ref Input- sets the bottom of the data range. A/D Ref Input+ sets the top of the data range. Since these inputs are directly related to the data range, it is important that a precision reference is used. The 485SDA10 has a 5V DC +/- 0.5% reference available. The voltage on A/D Ref Input+ must be at least 2.5V DC greater than A/D Ref Input-. The voltage difference between A/D Ref Input+ and A/D Ref Input- is referred to as the Reference Range.

Reference Range = (A/D Ref Input+) - (A/D Ref Input-)

Typically A/D Ref Input- is connected to Analog ground and A/D Ref Input+ is connected to +5V DC. Figure 2.1 in Chapter 2 shows the typical connections for a reference range of 0 to 5V DC.

Data Range

The data range of the A/D converter is determined by A/D Ref Input+ and A/D Ref Input-. A/D Ref Input- sets the bottom of the data range. Any input voltage that is less than or equal to the A/D Ref Input- will be read as a zero. A/D Ref Input+ sets the top of the data range. Any input voltage that is greater than or equal to the A/D Ref Input+ will be read as a 1023 (3FFh). The data range is as follows:

Data Range = (A/D Ref Input-) to (A/D Ref Input+)
Data Range = 0 to 1023
Data Range = 0 to 3FFh

Figure 4.1 shows the Data Range and A/D Ref Inputs relationship.

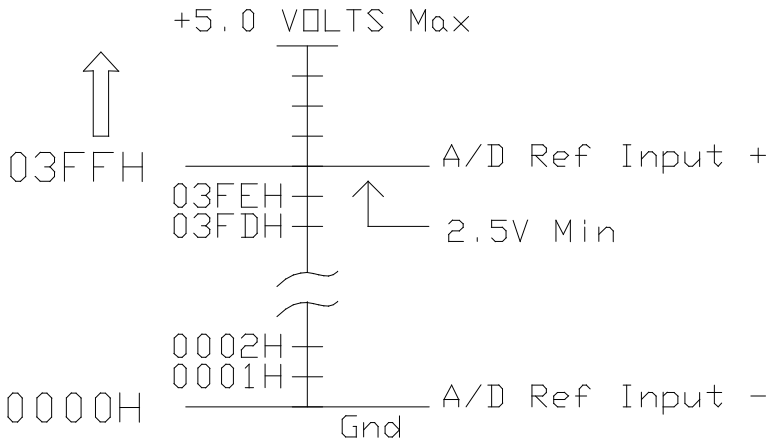

Figure 4.1 - A/D Converter Data Range

Converting Data

The data read from the 485SDA10 A/D converter is directly related to the A/D input channel and the reference range (discussed in previous sections). The 485SDA10 has a 10-bit A/D converter. A 10-bit A/D has 1024 possible output values, 0 to 1023 (0 to 3FFh). These 1024 output values are divided into equal steps over the reference range. The size of each step can be computed as follows:

$$\text{Step size} = (\text{Reference Range}) / 1023$$

The step size is also referred to as the resolution. Once the step size is known, all that is needed to determine the voltage of an A/D input is the number of steps. The data returned from the 485SDA10 is the number of steps. The voltage at the A/D inputs can be calculated as follows:

$$\text{Voltage} = (\# \text{ of steps}) * (\text{Step size})$$

Example 4.1 - Assume: A/D Ref. Input + = 5.0V DC and A/D Ref.Input - = 0V DC.

Therefore:

$$\text{Reference Range} = (\text{A/D Ref. Input } +) - (\text{A/D Ref. Input } -)$$

$$\text{Reference Range} = (5.0\text{V DC}) - (0\text{V DC})$$

$$\text{Reference Range} = 5.0\text{V DC}$$

$$\text{Step size} = (\text{Reference Range}) / 1023$$

$$\text{Step size} = (5.0\text{V DC}) / 1023$$

$$\text{Step size} = 4.8876 \text{ millivolts}$$

Example #1: A/D reading = 1023 (3FFH)

$$\text{A/D voltage} = \text{reading} * \text{step size}$$

$$\text{A/D voltage} = 1023 * 4.8876 \text{ millivolts}$$

$$\text{A/D voltage} = 5.0 \text{ Volts}$$

Example #2: A/D reading = 0

$$\text{A/D voltage} = 0 * 4.8876 \text{ millivolts}$$

$$\text{A/D voltage} = 0 \text{ Volts}$$

Example #3: A/D reading = 675 (2A3H)

$$\text{A/D voltage} = 675 * 4.8876 \text{ millivolts}$$

$$\text{A/D voltage} = 3.2991 \text{ Volts}$$

Chapter 5 - Software

This chapter covers programming techniques such as constructing a command string, receiving data and manipulating data. The various steps and examples are shown in QuickBasic. If you are programming in another language, these sections can be used as a guideline for programming the 485SDA10.

Read A/D Command

The Read A/D channels command returns two bytes for each channel read. The two bytes represent the most significant byte (MSB) and least significant byte (LSB) of the reading. The MSB is received first, followed by the LSB. This command requires a data byte. The data byte is used to specify the number of the highest channel to be read. All channels less than this channel will be read as well.

The steps to reading an A/D command are given below:

1. Constructing the command string:
Command\$ = "!" + CHR\$(addr) + "RA" + CHR\$(channel)
The value of **channel** is equal to the highest channel to be read.
2. Transmitting the command string:
Print #1, Command\$;
3. Receiving the data:
MSB\$ = INPUT\$(1, #1)
LSB\$ = INPUT\$(1, #1)
4. Manipulating the data:
reading = (ASC(MSB\$) * 256) + ASC(LSB\$)
The value of **reading** is the result of the A/D conversion.
5. Repeat Steps 3 & 4 until each channel has been completed.

Example 5.1 - Read A/D channels 1 and 0 of the module with an address of 5.

```
channel = 1
addr = 5
Command$ = "!" + CHR$(addr) + "RA" + CHR$(channel)
Print #1, Command$;
```

'Get the value of channel 1

MSB\$ = INPUT\$(1, #1)

LSB\$ = INPUT\$(1, #1)

reading1 = (ASC(MSB\$) * 256) + ASC(LSB\$)

'Get the value of channel 0

MSB\$ = INPUT\$(1, #1)

LSB\$ = INPUT\$(1, #1)

reading0 = (ASC(MSB\$) * 256) + ASC(LSB\$)

The value of **reading1** is the result of the A/D conversion on channel 1. The value of **reading0** is the result of the A/D conversion on channel 0.

Read Digital I/O Command

The Read Digital I/O command returns a byte which represents the states of the 3 digital input and 3 digital output states. Bits 3-5 correspond to the states of digital inputs 0-2, and bits 0-2 correspond to the states of digital outputs 0-2. If a bit is a 0 then the digital state of that digital I/O is LOW. If a bit is a 1 then the digital state of the I/O is HIGH.

The steps to reading a digital I/O command are given below:

1. Constructing the command string:
Command\$ = "!" + CHR\$(addr) + "RD"
2. Transmitting the command string:
Print #1, Command\$;
3. Receiving the data:
Reply\$ = INPUT\$(1, #1)
4. Manipulating the data:
states = ASC(Reply\$)
5. Determining an I/O's status
status = states AND mask
6. Repeat Step 5 until the status of each I/O has been determined.

By "ANDing" the value of **states** with the appropriate **mask** of an I/O line, the **status** of can be determined. If **status** is equal to zero then the I/O line is LOW. If **status** is not equal to zero then the I/O line is HIGH. Table 5.1 shows the **mask** values for each I/O.

Table 5.1 - Digital I/O Mask Values

I/O Line	Mask Values	
	Hexadecimal	Decimal
Digital Output #0	1H	1
Digital Output #1	2H	2
Digital Output #2	4H	4
Digital Input #0	8H	8
Digital Input #1	10H	16
Digital Input #2	20H	32

Example 5.2 - Determining the status of Digital Input #1 of the module with and address of 10.

mask = &H10

Command\$ = "!" + CHR\$(addr) + "RD"

Print #1, Command\$;

Reply\$ = INPUT\$ (1, #1)

states = ASC (Reply\$)

status = states AND mask

If **status** is equal to zero then Digital Input #1 is LOW. If **status** is not equal to zero then Digital Input #1 is HIGH.

Set Digital Output States

The Set Digital Output command is used to set the states of the 3 digital output lines. This command requires a data byte. The data byte is used to specify the output states. Bits 0-2 correspond to the states of digital outputs 0-2. If a bit is a 0 then the output will be set LOW. If a bit is a 1 then the output will be set HIGH. NOTE: This command ignores Bits 3-7 of the data byte.

The steps to setting the digital output states are given below:

- 1) Constructing the command string:
 - a) Set Appropriate Outputs HIGH

states = states OR mask

By "ORing" the current **states** with the appropriate **mask** of a digital output (given in Table 5.1), the output's data bit will be set to a "1" (which will be set HIGH).

- b) Set Appropriate Outputs LOW
states = states AND (NOT(mask))
 By “ANDing” the current **states** with the complement of the appropriate **mask** of a digital output (given in Table 5.1), the output’s data bit will be set to a “0” (which will be set LOW).
 - c) Construct the string
Command\$ = “!0SO” + CHR\$(states)
- 2) Transmitting the command string:
Print #1, Command\$;

Example 5.3 - Set Digital Output #0 HIGH and Digital Output #2 LOW of the module with an address of 5.

addr = 5

‘ Set bit 0 of states to make Digital Output #0 HIGH

states = states OR 1

‘ Clear bit 2 of states to make Digital Output #2 LOW

states = states AND (NOT(4))

Command\$ = “!” + CHR\$(addr) + “SO” + CHR\$(states)

Print #1, Command\$;

Digital Output #0 will be set HIGH. Digital Output #2 will be set LOW. Digital Output #1 will not change. Note that the variable **states** is assumed to be value from Example 5.2.

Set Module Address

The Set Module Address command is used to change the address of a 485SDA10. This command requires a data byte. The data byte is used to specify the new address of the unit. The address of a module is stored in non-volatile memory.

The steps to setting a module address are given below:

- 1) Constructing the command string:
Command\$ = “!” + CHR\$(addr) + “SO” + CHR\$(newaddr)
 Where **{addr}** is the current address of the module and **{new address}** is a byte representing the new address.
- 2) Transmitting the command string:
Print #1, Command\$

Example 5.4 – Change the address of a model from 5 to 10.

addr = 5

newaddr = 10

Command\$ = “!” + CHR\$(addr) + “SA” + CHR\$(newaddr)

Print #1, Command\$

Set Power-up States Command

The Set Power-up States command is used to set the states of the digital outputs at power-up. This command requires a data byte. The data byte is used to specify the power-up output states. Bits 0-2 correspond to the power-up states of digital outputs 0-2. If a bit is a 0 then the output will be set LOW at power-up. If a bit is a 1 then the output will be set HIGH at power-up. Refer to Table 3.6.

NOTE: This command ignores bits 3-7 of the data byte.

The steps to setting a module’s power up states are given below:

1) Construct the command string:

a) Set appropriate outputs HIGH

states = states OR mask

By “ORing” the current **states** with the appropriate

mask of a digital output given in Table 5.1, the output’s data bit will be set to a “1” (HIGH).

b) Set appropriate outputs LOW

states = states AND (NOT(mask))

By “ANDing” the current **states** with the complement of the appropriate **mask** of a digital output given in Table 5.1, the output’s data bit will be set to a “0” (LOW).

c) Construct the string

Command\$ = “!” + CHR\$(addr) + “SS” + CHR\$(states)

Where **addr** is the module’s address.

2) Transmitting the command string:

Print #1, Command\$

Example 5.5 – Set digital outputs 0 and 1 HIGH and digital output 2 LOW on the module with address 5.

addr = 5

states = 0

‘ Set bit 0 of states to make digital output 0 HIGH

states = states OR 1

‘ Set bit 1 of states to make digital output 1 HIGH

states = states OR 2

‘ Clear bit 2 of states to make digital output 2 LOW

states = states AND (NOT(4))

Command\$ = “!” + CHR\$(addr) + “SS” + CHR\$(states)

Print #1, Command\$

At power-up digital output 0 will be HIGH, digital output 1 will be HIGH, and digital output 2 will be LOW.

Set Turn-around Delay

The Set Turn-around Delay command sets the amount of time the 485SDA10 waits to respond after executing a command. This delay is necessary when two RS-485 transmitters are sharing a pair of wires to ensure that two transmitters are not enabled at the same time. Refer to B&B Electronics’ free RS-422/RS-485 Application Note for more information on RS-422/485. The turn-around delay is stored in non-volatile memory. This command requires a data byte. The data byte is used to specify the turn-around delay. One unit of turn-around delay is equal to the transmission time of one character. This transmission time can be computed as follows:

$$\text{time} = (1 / \text{baud rate}) * 10$$

The steps to setting a module’s turn-around delay are given below:

- 1) Constructing the command string:

Command\$ = “!” + CHR\$(addr) + “SC” + CHR\$(delay)

Where **addr** is the module’s address and **delay** is the turn-around delay. Refer to Chapter 3 for more information on turn-around delay.

- 2) Transmitting the command string:

Print #1, Command\$

Example 5.6 – Set the turn-around delay on the module with address 5 to 100 character transmission times.

addr = 5

delay = 100

Command\$ = “!” + CHR\$(addr) + “SC” + CHR\$(delay)

Print #1, Command\$

The module at address 5 will now have a turn-around delay of 100 character transmission times.

Read Module Configuration

The Read Module Configuration command reads the 485SDA10's address first, then the power-up states, and finally the turn-around delay.

The steps to reading a module's configuration are given below:

- 1) Constructing the command string:
Command\$ = "!" + CHR\$(addr) + "RC"
Where **addr** is the module's address.
- 2) Transmitting the command string:
Print #1, Command\$
- 3) Receiving the address data:
Reply\$ = INPUT\$(1,#1)
- 4) Determining the address:
address = ASC(Reply\$)
- 5) Receiving the power-up states data:
Reply\$ = INPUT\$(1,#1)
- 6) Determining the power-up states:
states = ASC(Reply\$)
Refer to Read Digital I/O earlier in this chapter for the steps to determine the status of individual output states.
- 7) Receiving the turn-around delay data:
Reply\$ = INPUT\$ (1,#1)
- 8) Determining the turn-around delay:
delay = ASC(Reply\$)

Example 5.7 – Determining the configuration of the module with an address of 10.

```
addr = 10
Command$ = "!" + CHR$(addr) + "RC"
Print #1, Command$
' Determine the module's address
Reply$ = INPUT$ (1,#1)
address = ASC(Reply$)
' Determine the module's power-up states
Reply$ = INPUT$ (1,#1)
states = ASC(Reply$)
' Determine the module's turn-around delay
Reply$ = INPUT$ (1,#1)
delay = ASC(Reply$)
```

Appendix A: Adding Data Field Confirmation

With serial communications in a laboratory environment, the possibility of a communication error occurring is minimal. However, in a harsh or an industrial environment the possibility increases. A communication error occurs when a bit transmitted as a “1” is received as a “0” or vice versa. If the 485SDA10 receives an error in one or more of the first four command characters (“!0xx”), the unit will not execute the command. However, if the 485SDA10 receives a communication error on a data byte (channel byte for Read Analog command or state byte for Set Output State command), the command will be executed since the unit has no way of knowing that there was an error.

To provide the 485SDA10 with a way of detecting errors in the data fields, an additional set of commands can be used. This set of commands begins with the “#” (23h) character, instead of the “!” (21h) character. Refer to Table A-1. With these commands every data byte that is transmitted or received is followed by its complement.

Example A.1 - To read A/D channel zero:

Command syntax:

#{addr}RA{00}{FF}

Response syntax:

{ch0 msb}{~ ch0 msb}{ch0 lsb} {~ ch0 lsb}

Where “~” is used to indicate the “complement of.”

If A/D channel 0 has a reading of 1, the following would be received:

{00}{FF}{01}{FE}

Where FFh is the complement of 0 and FEh is the complement of 1. The complement of number “x” can be calculated in QuickBasic as follows:

comp = (NOT x) AND &HFF

Table A-1 Extended Commands

Function	Command	Response
Read A/D Channels	# $\{addr\}RA\{x\}\{\sim x\}$	{chxmsb}{ \sim chxmsb}{chxlsb} { \sim chxlsb}{ch(x-1)msb}... {ch0msb} { \sim ch0msb}{ch0lsb}{ \sim ch0lsb}
Read Digital I/O	# $\{addr\}RD$	{I/O states}{ \sim I/O states}
Set Output States	# $\{addr\}SO\{x\}\{\sim x\}$	no response
Set Module Address	# $\{addr\}SA\{new\ addr\}\{\sim new\ addr\}$	no response
Set Power-up States	# $\{addr\}SS\{x\}\{\sim x\}$	no response
Set Turn-around Delay	# $\{addr\}SC\{x\}\{\sim x\}$	no response
Read Configuration	# $\{addr\}RC$	{addr}{ \sim addr}{powerup states}{ \sim powerup states}{turn-around delay}{ \sim turn-around delay}

Where “x” is the required data byte and “ \sim ” signifies the complement of the specified byte.

Appendix B: Analog Input Impedance

When interfacing with an A/D converter, it is important that the device you are connecting can drive the A/D input. To determine if your device can drive an A/D input, there are three factors you must consider:

- Output impedance of the device
- Input impedance of A/D
- A/D sampling time

The goal is to have the voltage at the A/D input settle to a voltage close to the output voltage of the device in a time frame that is less than the A/D sampling time. (Close to means a value significantly less than the resolution of the A/D). If the voltage does not settle fast enough, errors will occur in the reading, resulting in a loss of resolution.

The next section, titled “Simplified Analog Input Analysis,” contains information from Texas Instruments data sheet on the TLC1543. The TLC1543 is the A/D converter that is used on the 485SDA10. This section provides a simplified calculation which can be used to determine the maximum output impedance the device can have to settle the A/D input to a voltage within one half LSB.

For the 485SDA10:

$$t_c = 100\mu s$$

Using this information:

$$R_s \leq 170k\Omega$$

If the output impedance of your device is 170k Ω , you should figure an additional error of ½ LSB.

It should be pointed out that **this is a simplified analysis** and there other several other factors that must be considered (pin capacitance, noise immunity, etc.). The data sheet for the TLC1543 states that “The driving source impedance should be less than or equal to 1k Ω .” B&B Electronics recommends placing a voltage follower between the 485SDA10 and any device with output source impedance greater than 1k Ω .

Simplified Analog Input Analysis

Using the equivalent circuit in Figure B-1, the time required to charge the analog input capacitance from 0 to V_s within $\frac{1}{2}$ LSB can be derived as follows:

The capacitance charging voltage is given by

$$V_c = V_s(1 - e^{-t_c/R_t C_i}) \quad (1)$$

where

$$R_t = R_s + r_i$$

The final voltage to $\frac{1}{2}$ LSB is given by

$$V_c(1/2 \text{ LSB}) = V_s - (V_s/2048) \quad (2)$$

Equating equation 1 to equation 2 and solving for time t_c gives

$$V_s - (V_s/2048) = V_s(1 - e^{-t_c/R_t C_i}) \quad (3)$$

and

$$t_c(1/2 \text{ LSB}) = R_t \times C_i \times \ln(2048) \quad (4)$$

Therefore, with the values given the time for the analog input signal to settle is

$$t_c(1/2 \text{ LSB}) = (R_s + 1\text{k}\Omega) \times 60\text{pF} \times \ln(2048) \quad (5)$$

This time must be less than the converter sample time shown in the timing diagrams.

V_i = Input Voltage at A0 - A10

V_s = External Driving Source Voltage

R_s = Source Resistance

r_i = Input Resistance

C_i = Equivalent Input Capacitance

*Driving source requirements:

- Noise and distortion for the source must be equivalent to the resolution of the converter.
- R_s must be real at the input frequency.

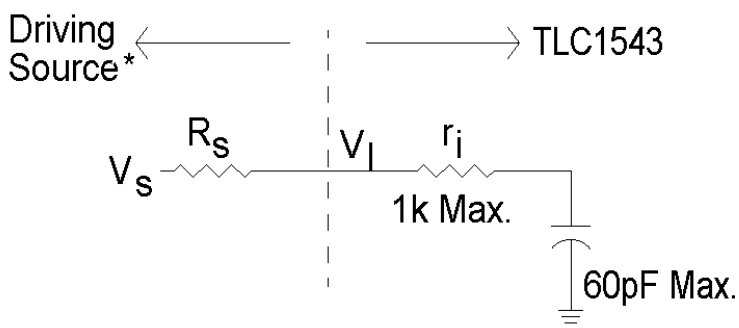

Figure B-1. Equivalent Input Circuit Including the Driving Source

Appendix C: Decimal to HEX to ASCII Table

Table C-1: Decimal to HEX to ASCII Table

DECIMAL to HEX to ASCII CONVERSION TABLE												
DEC	HEX	ASCII	KEY	DEC	HEX	ASCII	DEC	HEX	ASCII	DEC	HEX	ASCII
0	0	NUL	ctrl @	32	20	SP	64	40	@	96	60	`
1	1	SOH	ctrl A	33	21	!	65	41	A	97	61	a
2	2	STX	ctrl B	34	22	"	66	42	B	98	62	b
3	3	ETX	ctrl C	35	23	#	67	43	C	99	63	c
4	4	EOT	ctrl D	36	24	\$	68	44	D	100	64	d
5	5	ENQ	ctrl E	37	25	%	69	45	E	101	65	e
6	6	ACK	ctrl F	38	26	&	70	46	F	102	66	f
7	7	BEL	ctrl G	39	27	'	71	47	G	103	67	g
8	8	BS	ctrl H	40	28	(72	48	H	104	68	h
9	9	HT	ctrl I	41	29)	73	49	I	105	69	i
10	A	LF	ctrl J	42	2A	*	74	4A	J	106	6A	j
11	B	VT	ctrl K	43	2B	+	75	4B	K	107	6B	k
12	C	FF	ctrl L	44	2C	,	76	4C	L	108	6C	l
13	D	CR	ctrl M	45	2D	-	77	4D	M	109	6D	m
14	E	SO	ctrl N	46	2E	.	78	4E	N	110	6E	n
15	F	SI	ctrl O	47	2F	/	79	4F	O	111	6F	o
16	10	DLE	ctrl P	48	30	0	80	50	P	112	70	p
17	11	DC1	ctrl Q	49	31	1	81	51	Q	113	71	q
18	12	DC2	ctrl R	50	32	2	82	52	R	114	72	r
19	13	DC3	ctrl S	51	33	3	83	53	S	115	73	s
20	14	DC4	ctrl T	52	34	4	84	54	T	116	74	t
21	15	NAK	ctrl U	53	35	5	85	55	U	117	75	u
22	16	SYN	ctrl V	54	36	6	86	56	V	118	76	v
23	17	ETB	ctrl W	55	37	7	87	57	W	119	77	w
24	18	CAN	ctrl X	56	38	8	88	58	X	120	78	x
25	19	EM	ctrl Y	57	39	9	89	59	Y	121	79	y
26	1A	SUB	ctrl Z	58	3A	:	90	5A	Z	122	7A	z
27	1B	ESC	ctrl [59	3B	;	91	5B	[123	7B	{
28	1C	FS	ctrl \	60	3C	<	92	5C	\	124	7C	
29	1D	GS	ctrl]	61	3D	=	93	5D]	125	7D	}
30	1E	RS	ctrl ^	62	3E	>	94	5E	^	126	7E	~
31	1F	US	ctrl _	63	3F	?	95	5F	_	127	7F	DEL

FEDERAL COMMUNICATIONS COMMISSION RADIO FREQUENCY INTERFACE STATEMENT

Class A Equipment

This equipment has been tested and found to comply with the limits for Class A digital device, pursuant to Part 15 of the FCC Rules. These limits are designed to provide reasonable protection against harmful interference when the equipment is operated in a commercial environment. This equipment generates, uses, and can radiate radio frequency energy and, if not installed and used in accordance with the instructions, may cause harmful interference to radio communications. Operation of this equipment in a residential area is likely to cause harmful interference, in which case the user will be required to correct the interference at personal expense.