

K-type Thermocouple Amplifier

Model TCDA



Description

The TCDA provides a low cost solution for temperature measurement. The TCDA amplifies the low voltages of a K-type thermocouple to voltages that can be read by Analog to Digital Converters. The TCDA is pin compatible with B&B Electronics' SDAXX and ADIO12 data acquisition modules. The TCDA can also be used with the SPDA line of data acquisition modules. With the TCDA and one of the Data Acquisition modules mentioned above, temperature readings can be taken and converted to RS-232 or RS-485. The standard TCDA can measure temperature between -50°C and 200°C. In addition, the TCDA can be modified at the factory so that higher temperatures can be measured. Software is included with the TCDA. This software can be used with the ADIO12, SPDA and SDAXX line of data acquisition modules to read the TCDA.

Features

- 2 channels for K-type thermocouples.
- Measure temperatures between -50°C and +200°C.
- Cold Junction Compensation.
- Pin compatible with B&B Electronics' line of SDAXX and ADIO12 Data Acquisition Modules.
- The TCDA can be modified at factory for higher temperature ranges.
- Includes software used with SDAXX, SPDA and ADIO12 to read voltages from TCDA module.

Connections

The TCDA requires several different connections. Thermocouple connections are made using terminal blocks. A 2.5mm power jack is used to provide power to the module, and connections to a data acquisition module are made through a DB-25 (male) connector. Table 2 shows the DB-25 pin assignments, and Table 2 shows the terminal block connections.

Table 1: DB-25 (male) Pin Assignments

DB-25 Pin #	Function	DB-25 Pin #	Function
1	GND	14	-----
2	-----	15	-----
3	-----	16	-----
4	-----	17	Connected to pin 18
5	-----	18	Connected to pin 17
6	-----	19	GND
7	GND	20	-----
8	TC channel #0	21	-----
9	TC channel #1	22	-----
10	-----	23	-----
11	-----	24	-----
12	-----	25	-----
13	-----		

Table 1: Terminal Block Assignments

TB Label	Notes
T1(+)	Thermocouple ch. 1; yellow wire of thermocouple connected to T1(+)
T1(-)	Thermocouple ch. 1; red wire of thermocouple connected to T1(-)
T2(+)	Thermocouple ch. 2; yellow wire of thermocouple connected to T2(+)
T2(-)	Thermocouple ch. 2; red wire of thermocouple connected to T2(-)

© B&B Electronics - March 1997

Phone: (815) 433-5100
Office Fax: (815) 433-5105
Tech Fax: (815) 433-5104
Sales Fax: (815) 433-5109

B&B electronics
MANUFACTURING COMPANY
707 Dayton Road -- P.O. Box 1040 -- Ottawa, IL 61350 USA

Home Page: www.bb-elec.com
E-mail: orders@bb-elec.com
support@bb-elec.com
catrqt@bb-elec.com

Figure 1: Block Diagram of Connections Required for TCDA Thermocouples

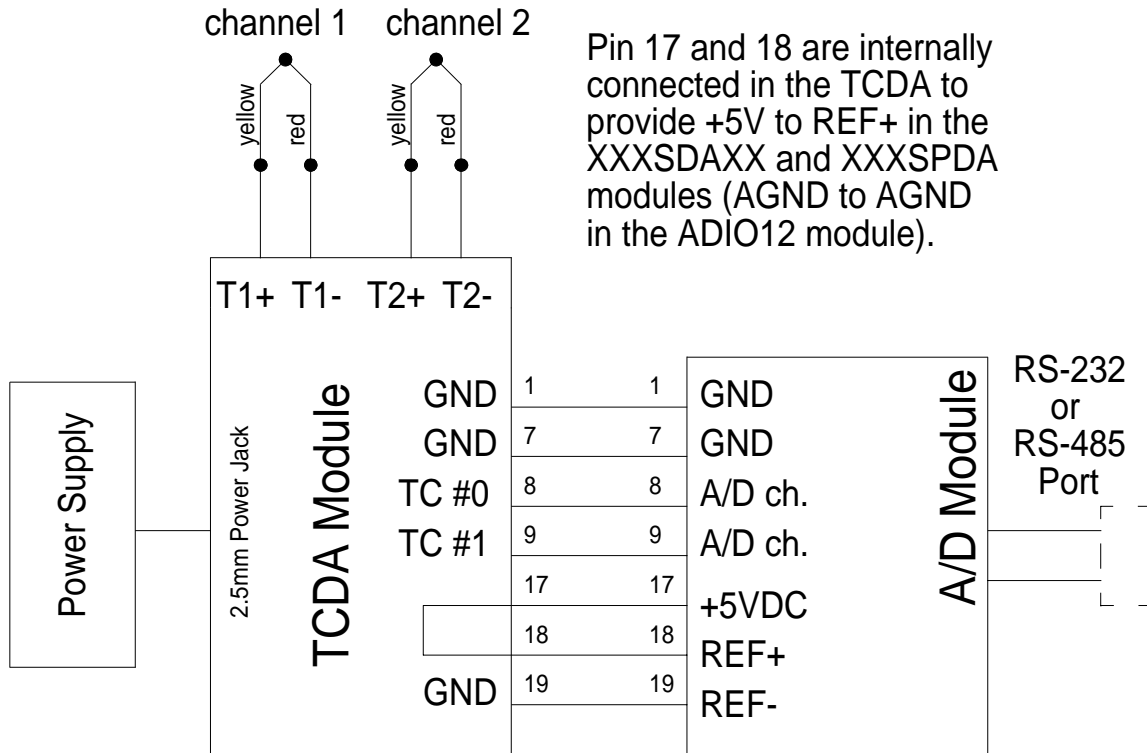

Specifications

Size:	4.8" x 2.2" x 0.9"
Channels:	2
Resolution:	20mV/ °C
Temperature Measurement Range:	-50°C to 200°C
Temperature Measurement Error:	±3°C over -50°C to 200°C range
Output Voltage Range:	0 to 5VDC (-50°C to 200°C)
Input Offset Voltage:	150µV maximum
Input Offset Voltage Drift:	1.5µV/ °C
Operating Temperature Range:	0°C to 70°C
Thermocouple Connections:	Terminal blocks
A/D Converter Connections:	DB-25 (male) connector
Power Connections:	2.5mm power jack
Power Requirements:	12 to 16VDC @10mA; 232PS suggested power supply (not included)