

Analog Outputs

Analog Outputs use a D/A converter or module which has one or more channels of D/A (Digital to Analog) Output.

Key Specifications are:

1. Bits of Resolution
2. Range of Voltage or Current Outputs
3. Whether the analog output sources voltage/current or sinks voltage/current.
4. Rated Output Impedance Specification

Resolution

The number of bits of resolution was previously covered in the analog input section, analog outputs typically have similar resolution to analog inputs, except that they are outputs.

For example, with 12 bits of resolution, and a range of 0 to 5 volts, each step is about 1.22 mV, If the range is 10 volts, each step is nearly 2.5 mV.

Voltage range divided by the number of steps = the output voltage of each step.

If the range is 0 to 20mA we lose everything lower than 4 mA, using 4 to 20 mA. Only 16 mA remain. That means the first 819 steps are lost, leaving 3277 steps of useable range.

Range of Voltage Outputs

+/- 150mV, +/-500mA, +/- 1 V, +/-5 V, +/- 10, +/- 20mA.



International Headquarters: 707 Dayton Road - PO Box 1040 - Ottawa, IL 61350 USA
815-433-5100 Fax 433-5104 www.bb-elec.com orders@bb-elec.com support@bb-elec.com

European Headquarters: Westlink Commercial Park - Oranmore, Co. Galway, Ireland
+353 91 792444 Fax +353 91 792445 www.bb-europe.com orders@bb-europe.com support@bb-europe.com

-twr2011.07.27

Sourcing or Sinking Current

Simplified Diagram
 Sourcing VS Sinking

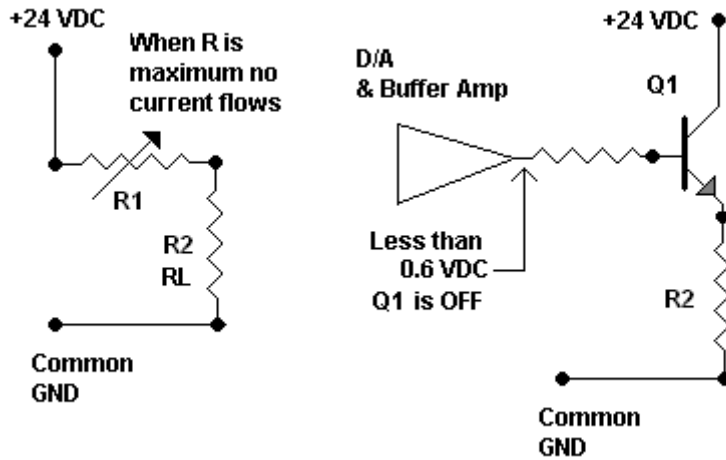
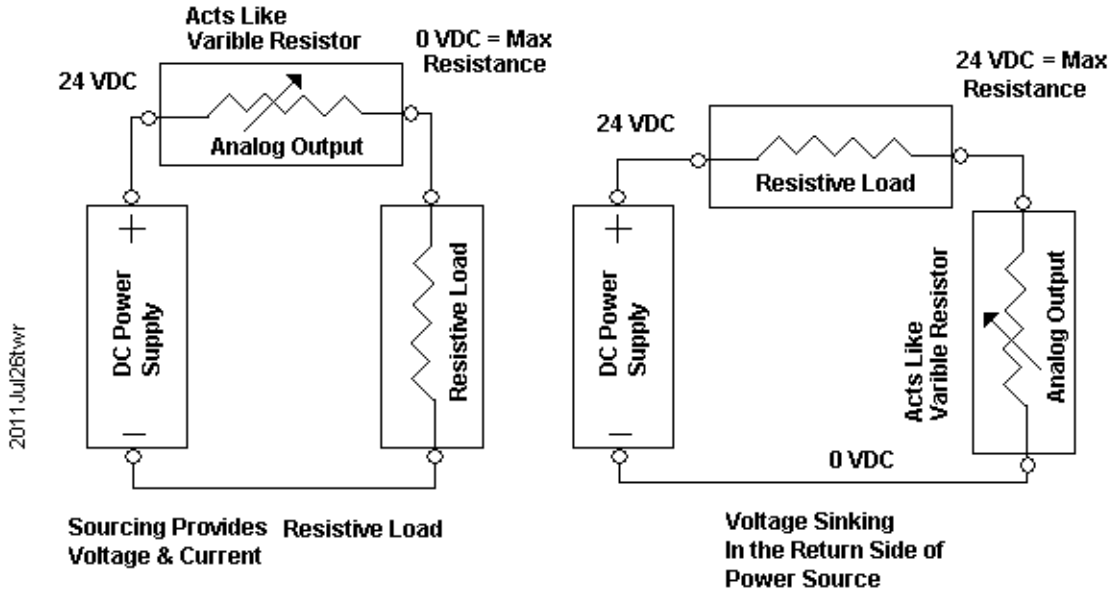

When an analog output sources voltage, you can connect a voltmeter to the output and ground, and measure a voltage that varies with the value of the D/A input. The voltage may be rather limited, for example, an Op Amp (Operational Amplifier) may only source a few mA. The value of R2 (Schematic) must not be lower than the rated load resistance for voltage output.



International Headquarters: 707 Dayton Road - PO Box 1040 - Ottawa, IL 61350 USA
 815-433-5100 Fax 433-5104 www.bb-elec.com orders@bb-elec.com support@bb-elec.com

European Headquarters: Westlink Commercial Park - Oranmore, Co. Galway, Ireland
 +353 91 792444 Fax +353 91 792445 www.bb-europe.com orders@bb-europe.com support@bb-europe.com

If we have a current sourcing output, and the value is a higher resistance, then the voltage sourced may not be high enough to provide 20mA of current. However, we may be able to obtain 20mA of current when the load has a lower resistance. There is usually a rating for minimum load resistance, if the resistance is too low on the device, then excess current will be provided, causing circuit damage.

When a analog output sources voltage, you can connect a voltmeter to the output and ground, and measure a voltage that varies with the value of the D/A input. The voltage may be rather limited, for example, a Op Amp (Operational Amplifier) may only source a few mA. The value of R2 (Schematic on next page) must not be lower than the rated load resistance for voltage output

If we have a current sourcing output, and the value is a higher resistance, then the voltage sourced may not be high enough to provide 20mA of current. However, we may be able to obtain 20mA of current when the load has a lower resistance. There is usually a rating for minimum load resistance, if the resistance is too low on the device, then excess current will be provided, causing circuit damage.

If the current sourcing output has a very low source resistance, we may need to provide some added resistance in series with the source so we don't exceed the current rating of the device reading the current.

In the real world, the D/A and buffer amplifier must be able to source enough voltage to provide 20mA through Q1 to the load. Usually there is voltage gain and negative feedback to stabilize the voltage. In the figure above, Q1 must handle 0.28 watts to develop 10 volts @ 20mA. In the current sinking figure below, Q1 must handle 0.2 watts of heating power.

If the output is sinking type, to see the effect of a varying current you require an external power source, and load resistor to develop the voltage across, before the sinking output. The resistor must drop all the voltage at 20mA except for the rated value of the analog output at 20mA. In the case of 20mA rated current, the rated load impedance of the sinking output is 500 ohms, 10 volts can be measured across the output, so with a 24 volt source voltage, 14 volts is dropped across a source resistance of 700 ohms. The minimum load value for a sinking output is ≥ 450 ohms for about 22.2 mA of current.

Output Impedance - Voltage Output

A low output impedance will not change much with loading, provided the loading is above the rated value in ohms or Kohms. When the voltage is measured with a DVM before connecting the A/D output to a load, it will remain the same voltage after connecting it.



International Headquarters: 707 Dayton Road - PO Box 1040 - Ottawa, IL 61350 USA
815-433-5100 Fax 433-5104 www.bb-elec.com orders@bb-elec.com support@bb-elec.com

European Headquarters: Westlink Commercial Park - Oranmore, Co. Galway, Ireland
+353 91 792444 Fax +353 91 792445 www.bb-europe.com orders@bb-europe.com support@bb-europe.com

-twr2011.07.27