

Data Acquisition Basics

Data Acquisition hardware devices provide an interface between electrical signals a computer can read or can output to control things in the real world. To understand the hardware of data acquisition you need some basic knowledge of electronics.

A computer is equipped with Ports or memory locations reserved for inputs and outputs to access the outside world. A computer needs software to read the inputs, to write the outputs, to display the values read or to accept user inputs from keyboards or switches.

With hardware present in older computers, a user could write a program using GW Basic, QuickBasic or C to access the ports using direct in-port (INP – QuickBasic) and out-port (OUT – QuickBasic) commands to read or set the value. Some computer languages provided “Peek” to read a location value, and “Poke” to write a value. Examples of digital inputs or outputs could be found in computers with Joystick and trigger inputs, and in the parallel port 8 bits of parallel data, or control line outputs such as Strobe, or to read the control line inputs for Busy, Paper Error, or ACK (Acknowledge). Another output port on an XT/AT computer was a speaker digital port, a writing a 1 and 0 alternately at a fast enough rate would cause the speaker to click if done slowly for keystroke audible feedback or could generate audio tones if alternated at a audio rate up to several thousand times per second. That port was buffered from the speaker using a current sinking transistor to handle the additional current draw, and volume was limited with a resistor in series with the speaker coil and transistor. With a joystick or gameport card, there are digital inputs for Trigger or analog inputs for joystick and paddle controllers, reading the port would return a value from 0 to 255, depending on the paddle/joystick position. With sound cards installed, audio can digitized or output by other means.

With a digital input we can read two states, a high or low. A switch can be open or closed.

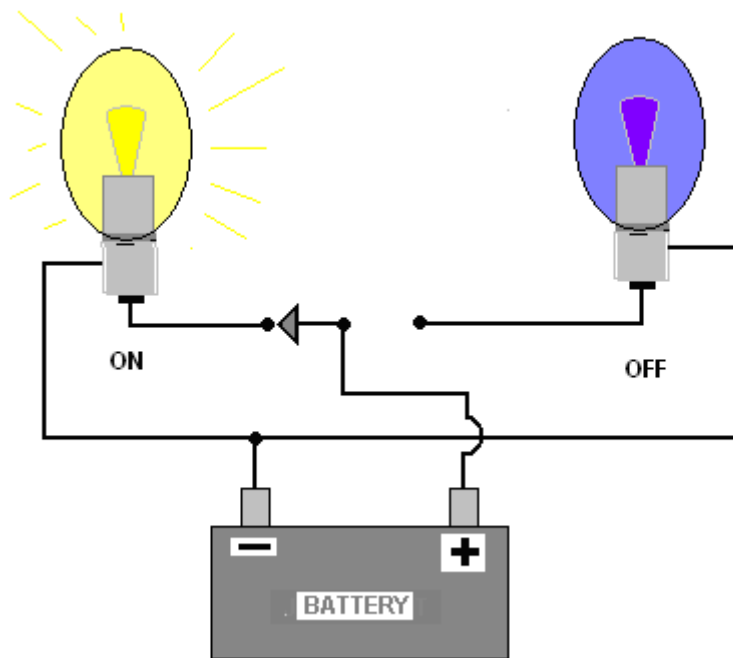

With a digital output, we can turn a light on or off, control a relay or turn a motor on or off. If we can turn a digital output on/off rapidly enough, we can vary the on/off time for PWM (Pulse Width Modulation) and effectively develop a average DC voltage anywhere between full on, full off, or with a 50% duty cycle, half the source voltage.

Analog Input With Voltage Increasing Over Time

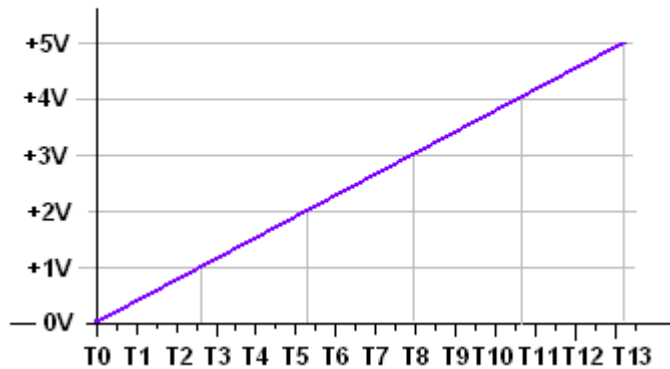

Many more real world inputs are a range of values, a range of DC voltages, analog inputs or analog outputs, some modules read a range from 0 to 5 VDC, 0 to 10 VDC, others from +/-150mV to +/-10VDC, while some inputs are 4-20mA or 0-20mA. Some analog inputs are designed to handle very low voltages such as thermocouples, RTD's, thermistor, pH or strain gauges, load cells or similar devices, AC or DC currents using magnetic sensors. Analog outputs are commonly DC voltages, such as 0 to 10VDC or 4-20mA. Such output voltages may be used to control the speed of motor drives, light intensity, or pump speed.

The range of Data Acquisition devices includes devices built into computer motherboards, PLCs, single board computers, internal hardware such as PCI cards, USB connected devices, serial connected devices such as RS232, RS422 or RS485, Ethernet Devices, or wireless devices connected using Wi-Fi or proprietary 900MHz or 2.4GHz radios with I/O or Modular I/O.

Digital input modules may include pulse or frequency counters to measure duration or intervals.

Another key point to consider is how many data points you want to monitor, and what is the typical or best sampling rate (how often you can read the data point or points), and what is the latency, difference between when the sample was obtained, and when you get it and can do something with it. One thing that affects the sampling rate is the data format of the request and response. More compact formats can be sampled faster, especially if 8 inputs can be read with one request, and the data returned in one byte, there is less overhead. With serial data acquisition at 9600 baud, the request and response data is 960 characters per second. If we have a 5 byte request for data, and two bytes of response, the minimum time for the data is about 137 times per second, but if we allow for 1 character time, between requests for data, and response, and another 1 character time between response, and next request, the best case is about 106 requests per second.

Digital Input Levels

A digital interface is used to sense a high or low, such as a switch closure. One side of a switch is connected to an input port, and the port is pulled high with a resistor and voltage source, or pulled low with a contact closure. The status of the port is read repeatedly to see when the input is high or low. When the device is read repeatedly, it is said to be "polled".

If the device is self-polling, it will read its' inputs, then output the value. Other self polling devices may repeatedly read the inputs until there is a change, then output data or trigger an interrupt to be read. Self-polling devices are less common, often designed for use in pairs, such as our 232IOEXT, where 8 inputs on one unit are transferred to the 8 outputs on another, or B&B wireless Modular I/O radios. (such as the ZZ9D-NA-LR) which reads the Slave's digital inputs, and analog inputs, then outputs them on the Master,



International Headquarters: 707 Dayton Road - PO Box 1040 - Ottawa, IL 61350 USA
815-433-5100 Fax 433-5104 www.bb-elec.com orders@bb-elec.com support@bb-elec.com

European Headquarters: Westlink Commercial Park - Oranmore, Co. Galway, Ireland
+353 91 792444 Fax +353 91 792445 www.bb-europe.com orders@bb-europe.com support@bb-europe.com

-twr2011.07.27

and reads the Master's inputs, then sends those to the Slave. (In P2P Point-To-Point mode, one unit is set as Master, the other as Slave.)

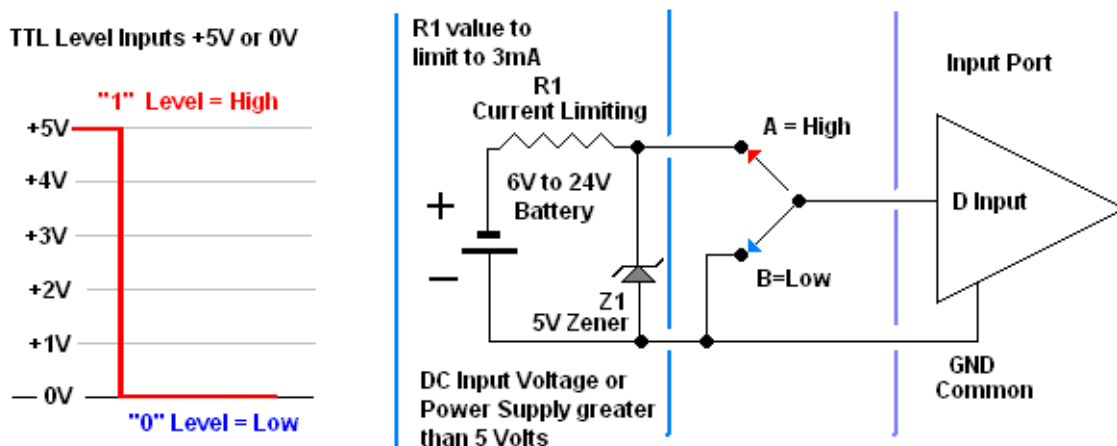

In the input circuit above, the A position High is Voltage Sourcing, and in the B position, the low Voltage Sinking. Any random voltages on the input line are sunk to ground to hold the input low. Input voltages above 5 volts are limited by applying the external voltage in place of the battery and dropping all the voltage above 5 volts across R1. The zener needs only enough current to zener, a few mV (2-3mV) is fine, the maximum is limited by the power rating of the zener. R1 is calculated by subtracting the zener voltage from the source to obtain the voltage for R1 and solving for $R = E/I$ with E = voltage in volts, I is current in amps, or 0.003A – for 24 volts, - 5V is $19/0.003$. About 6.3Kohms. Closest standard values are .6.8K or 4.7K.

As a "rule of thumb", unused digital inputs should be pulled Low unless pulled High internally.

Typical Circuitry for "Dry Contact" Digital Inputs

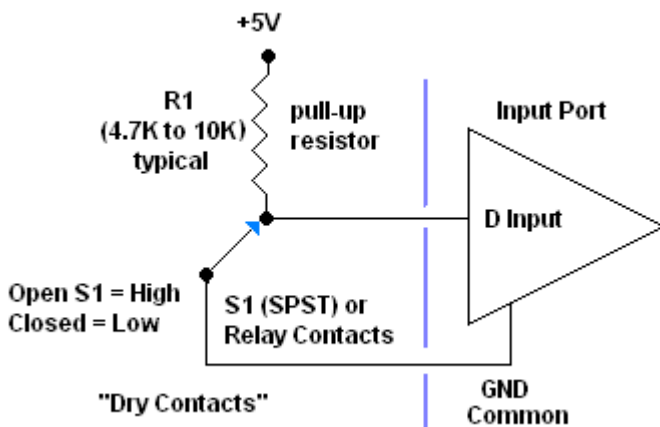

In many B&B DAQ modules, the pull-up or pull-down resistors must be added externally to the module, such as the 232SDA12, 485SDA12, 232SDD16, 485SDD16, 232SPDA, but the 232IOEXT includes the pull-up resistors internally. There is a DBM16 buffer module for the 232SDD16 or 485SDD16 that provides selectable Pull-ups for the inputs and current sinking for the outputs. Specifications for the DBM16 are in the back of the 232SDD16 & 485SCC16 manuals.

In 3rd party products from other suppliers, pull-ups are commonly provided, unless they are rated for "Wet Contacts". Wet Contacts require an active high above a specified voltage, or active low between GND and some higher voltage such as 3 VDC to below 0.6VDC. With Wet contacts additional circuitry is needed with real world inputs to make the low, low enough to meet the requirement, or the high, high enough. When internal pull-ups are provided, typically there is a DC voltage on the input.

Input Ratings for High and Low Vary

TTL Level Inputs +5V or 0V

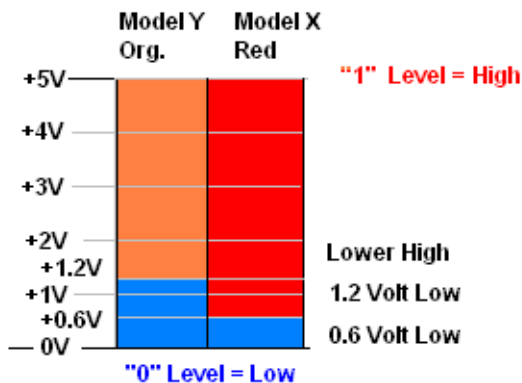
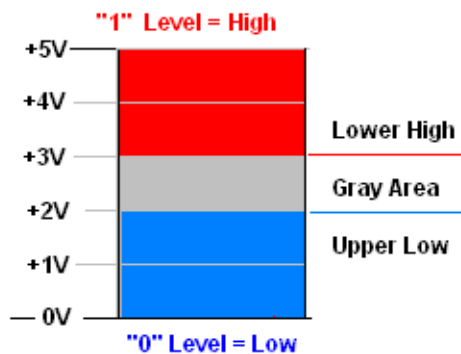

twr08/01

Extending the Input Range

Important specifications for digital inputs are:

1. Maximum voltage input rating (+5 TTL level inputs are typically 0 and 5 volts)
2. Voltage range for Low reading (TTL level low is usually less than 2 volts)
3. Voltage range for High reading (TTL level high is usually more than 3 volts)
4. Rated input impedance (ohms) (Higher ratings load the input voltage less)

The range between low threshold and high threshold is "indeterminate" meaning we don't know what the state will be in that area.

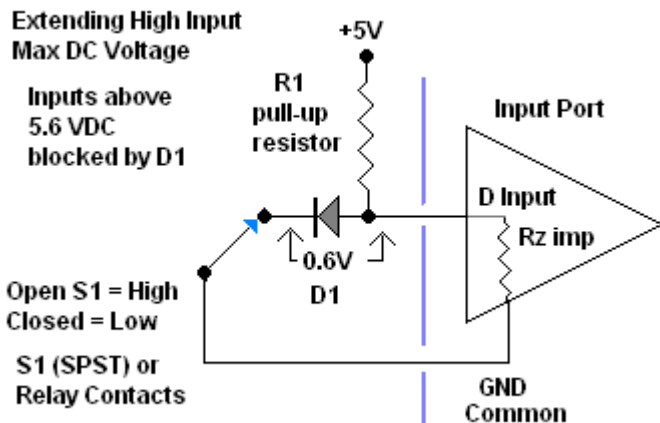

Often the device you need to connect to an input is rated at a higher voltage than the rating of the digital input of the DAQ module. Two ways to limit it, use a zener and input resistor, or use a silicon diode with the input side referenced to the max rated voltage of the input device. The low for the device must be higher than 0.7V since the diode drops 0.6V typically, but can range from 0.5V to 0.7V. The zener costs a bit more. A sequence of digital inputs and various values of zener can permit checking a voltage above or below the values of the zeners. This method is used on several of our products, such as Wireless modular I/O and on the DBM16.

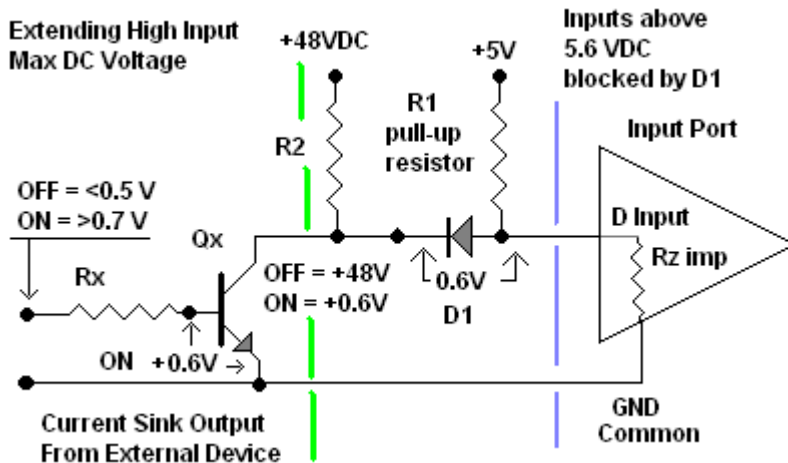

Highs & Lows Vary With Model
 Specs for Dry or Wet Inputs

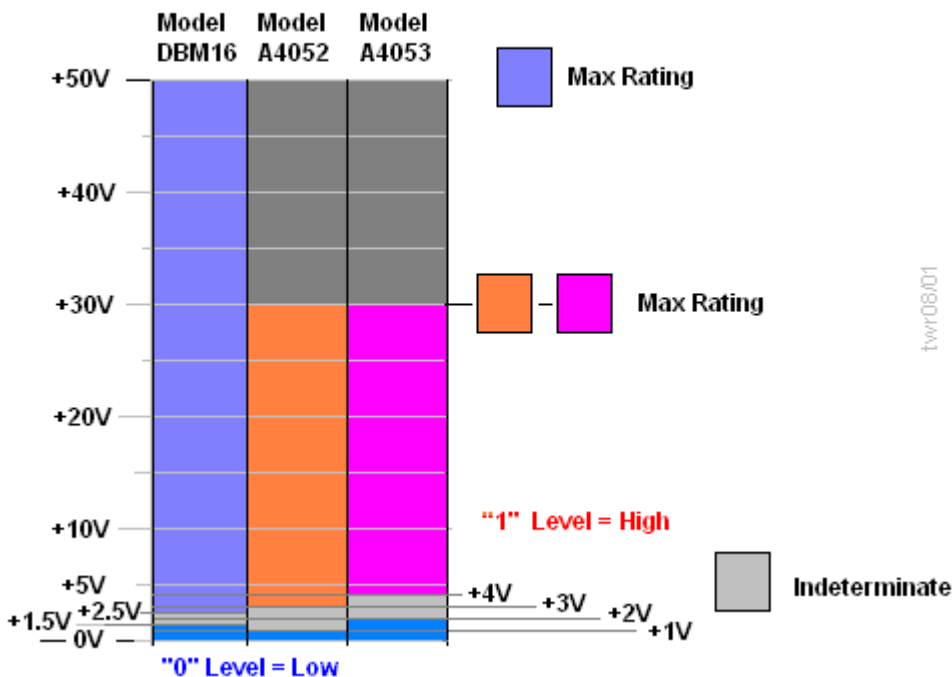

If a digital input has built-in pull-ups, you can usually read a voltage across the input. If you don't know input load rating of a digital input, put a 2.2k to 3.6K ohm resistor in series with the input voltage to limit the current. Then measure the DC level at the digital input. If it is lower, loading is occurring, resistance is



International Headquarters: 707 Dayton Road - PO Box 1040 - Ottawa, IL 61350 USA
 815-433-5100 Fax 433-5104 www.bb-elec.com orders@bb-elec.com support@bb-elec.com

European Headquarters: Westlink Commercial Park - Oranmore, Co. Galway, Ireland
 +353 91 792444 Fax +353 91 792445 www.bb-europe.com orders@bb-europe.com support@bb-europe.com

needed. A 2.2K to 3.6K resistor will limit the current to only 2-3mA for 5 volt sources. Usually a resistance is needed when connecting a voltage to the base of a transistor, Darlington pair or digital IC input.

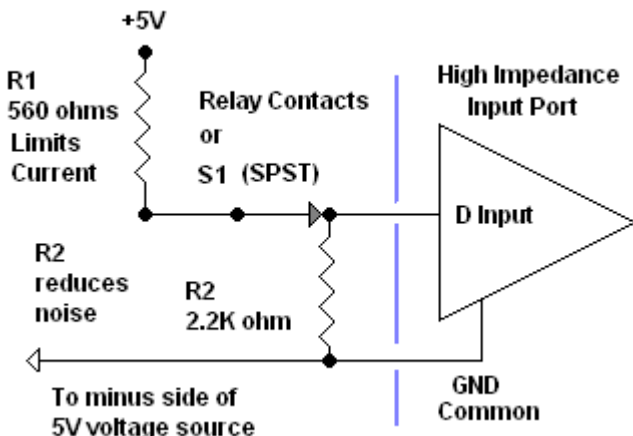

One problem with high impedance digital inputs is they can pick up noise, so some resistance across the input may be needed if the voltage source is applied through a switch or relay contacts. Also recommended is limiting voltage to the switch in the event of a short in the wiring. The resistors to source voltage (R1) and across the input (R2) need to be selected to meet the high and low requirements for the device. The values of R1 and R2 are selected to be about 4V for a high with S1 closed, and zero with S1 open. Usually if digital or analog inputs are very long, shielded cable should be used, with the shield connected to the Ground of the device or to earth ground if the both digital wires are carried within the cable.

For looks at other digital inputs, check the 232SDD16 manual, Chapter 4, pages 17-19, figures 4.1 to 4.4, and Appendix C, and UD128A8D manuals, Chapter 2, page 16, figures 2.3 to 2.8..

Isolated connections shown, and the use of LED for input and output signal indication is shown in several manuals for Digital Inputs & Outputs.

Introduction to Data Acquisition Part 2 covers D-In Counters & Digital OutputSection Part 3 covers Analog Inputs, Part 4, Analog Outputs.

Series Circuits

