

How Can I Extend the RS-232 Connections For A Casio QT-2100?

Many of our customers install and support various Point of Sale (POS) devices, and use our converters to extend RS-232 connections more than 50 feet/15 meters.

Casio sells a line of cash registers and POS (Point of Sale) devices with RS-232 serial connections. The customer needed to connect a Casio QT-2100 device with RS-232C connections that needed to be over 100 feet from the computer. The standard Casio diagram shows wiring directly to a computer, using a modified crossover cable for DTE to DTE (wired as below), so we needed to determine the connections using our 422CEC converter.

Example QT-2100 Connection Cable Directly to Computer

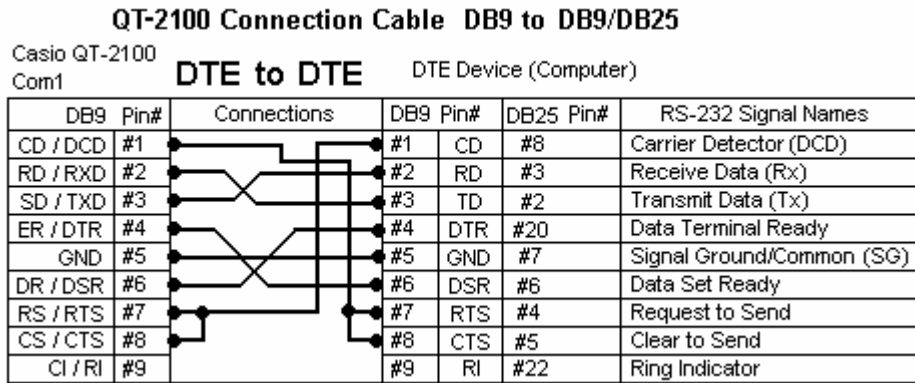

This figure shows the recommended connections. 6 signals are required, so to extend this many signals we must use the 422CEC converter which can handle 8 signals (channels). This converter has a DB25 Female RS-232 connection wired like a modem (DCE) and DB25 Male RS-422. Six data signals require 6 twisted pairs of wires for RS-422, plus a signal ground, so another pair is used for ground, and the cable shield tied to Chassis Ground at one end.

Using the 422CEC, what connections should I use from the QT-2100 to the 422CEC RS-232 side, between the Computer and 422CEC, and between the two 422CEC converters?

Connection Example 1: QT-2100 or Computer DB9 Male to 422CEC

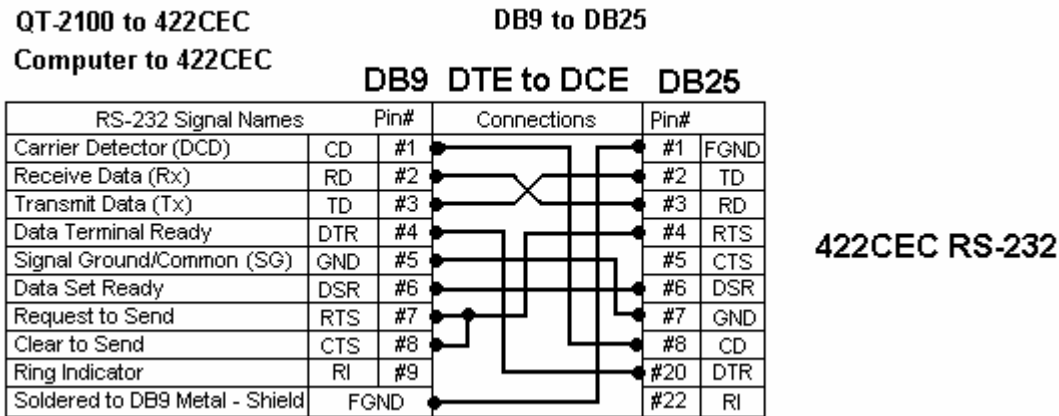

Note that the 422CEC is wired like a modem (DCE), so Transmit Data (TD) is an input, and Receive Data (RD) is an output. DTR is an input, DSR is an output, RTS is an input, CD is an output, so most connections go to the matching signal line, except the CTS is looped to RTS on the computer/register side, and connected to the 422CEC on the converter side

Connection Example 1: Computer DB25 Male to 422CEC

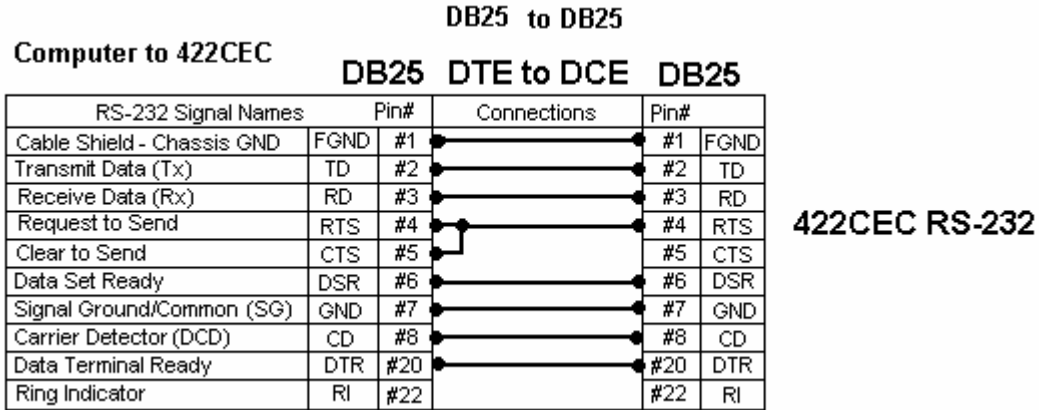

Connection Example 1: RS-422 Side Connections 422CEC to 422CEC

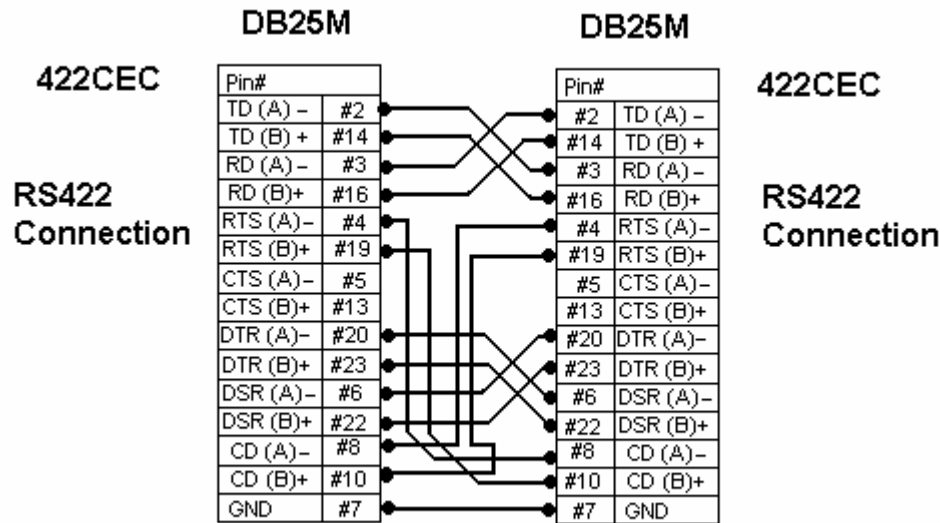

Note that on the RS422 side, TD(A) and TD(B) are outputs, and must connect to the RD(A) and RD(B) inputs, DTR(A) and DTR(B) are outputs, DSR(A) and DSR(B) are inputs, RTS(A) and RTS(B) are outputs, CD(A) and CD(B) are inputs. Each pair of signals should be on one twisted pair of wires so that

(see next page for example 2)

Connection Example 2 (below): QT-2100 or Computer to 422CEC

Modem Cable - Straight Conversion DB9 to DB25

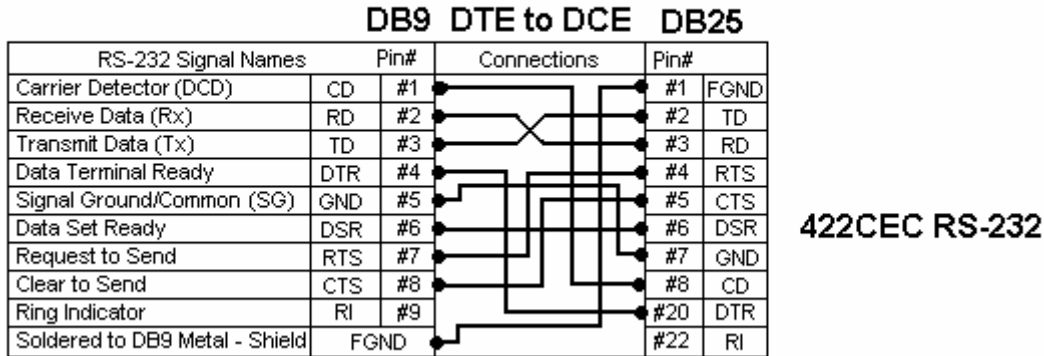

Note that this RS232 connection from the QT-2100 or Computer to the 422CEC can be made using one of our standard cables, such as the 232CAM or 232CAMS. Then the only special wiring is done on the RS422 side of the 422CEC. RI is not used, it is input on DTE devices.

When connecting from the DB25 Female connector into a computer with DB25 Male connector, use a straight through DB25M to DB25F cable.

Connection Example 2: RS-422 Side Connections 422CEC to 422CEC (match examples)

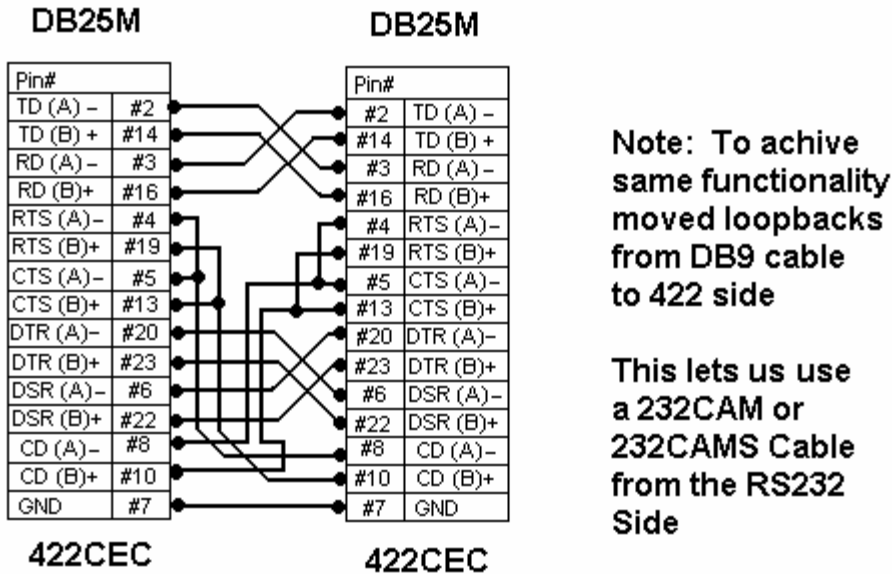

Note that the loopback connection of RTS to CTS and CD is connecting the RTS(A) output to CTS(A) and CD(A) inputs, and RTS(B) output to CTS(B) and CD(B) inputs. Outputs on either side are connected to Inputs on the other converter.

For other devices, see our FAQ – RS-232 Connections That Work! In our Tech Note library.

-twr