

This FAQ covers Single Direction use of current loop with transmitting devices.

Q: How do I connect the Current Loop Converter to my Current Loop device?

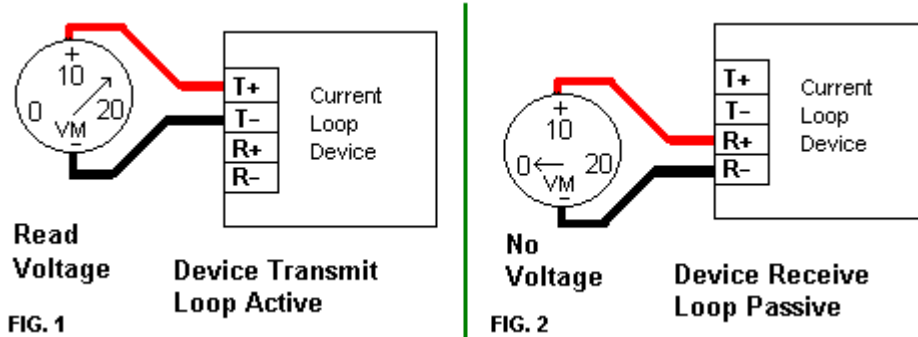

A: This Current Loop interface has two states, during the Mark state (no signal), current is flowing in each loop, transmit and receive. In the Space state, no current flows. Open circuit, an Active Current loop will have a DC voltage, a Passive loop will have no voltage.

Use a DC voltmeter to measure between T+ and T- to see if a DC voltage is present when the device is turned on, but T+ and T- are open circuit (not connected to anything but the voltmeter). If a DC voltage is present (FIG.1), it will generally be more than 1.2V DC, open circuit may be +5, +12 or more (depending on the Current Source Voltage, but should current limited to around 20mA closed circuit. If the T+ to T- wire pair has voltage, the converter Receive must be connected as a Passive device. If there is no voltage, the converter Receiver must be made Active. Measure and determine whether the device R+ and R- pair is active, if active, the converter Transmitter should be passive. If Receiver is Passive (FIG.2), the Transmit on the converter must be made Active.

In the figures which follow, the converter loops are passive, or active or one of each, similar wiring is shown for each of the 3 models. Download the data sheets for internal diagrams.

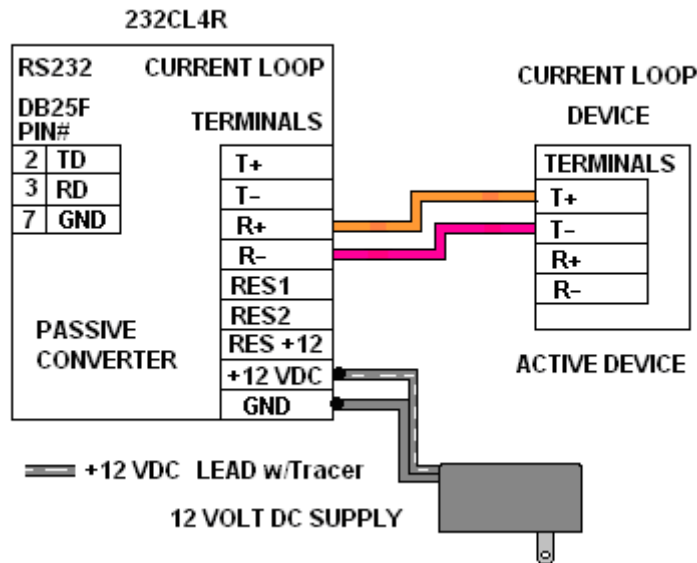

Fig. 3: 232CL4R Passive Converter – Active Device

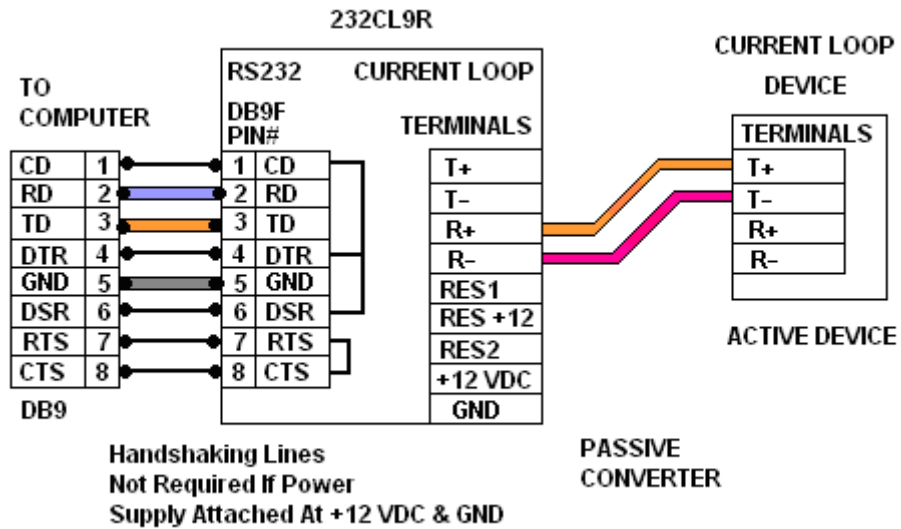

Fig. 4: 232CL9R Passive Converter – Active Device

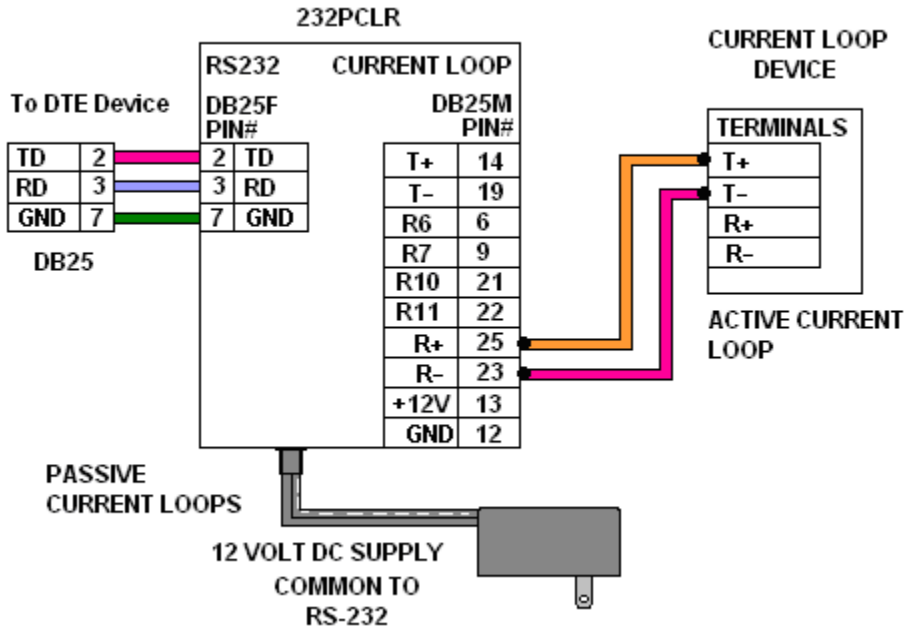

Fig. 5: 232PCLR Passive Converter – Active Device

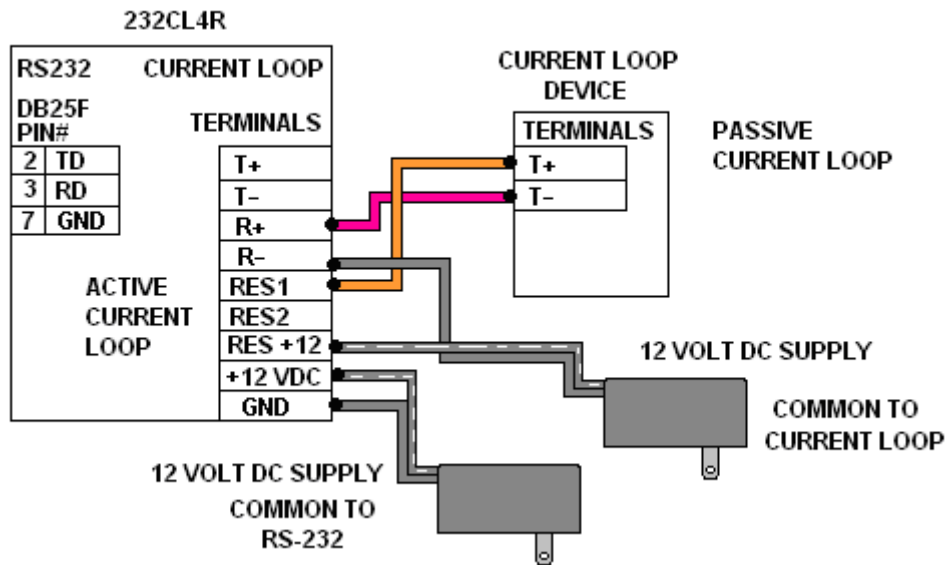

Fig.6: 232CL4R Active Converter – Passive Device

To maintain isolation between the RS-232 device and the Current Loop device, a separate isolated power supply should be used to make the Current Loops active. If the Current Loop is made active using the same supply as the RS232 side of the converter, there will be no protective isolation.

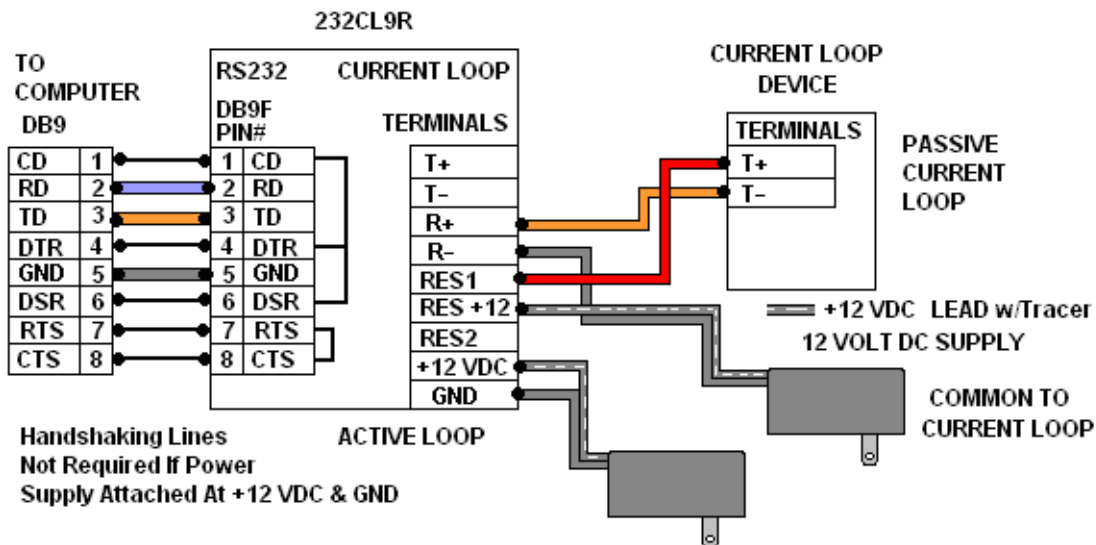

Fig. 7: 232CL9R Active Converter – Passive Device

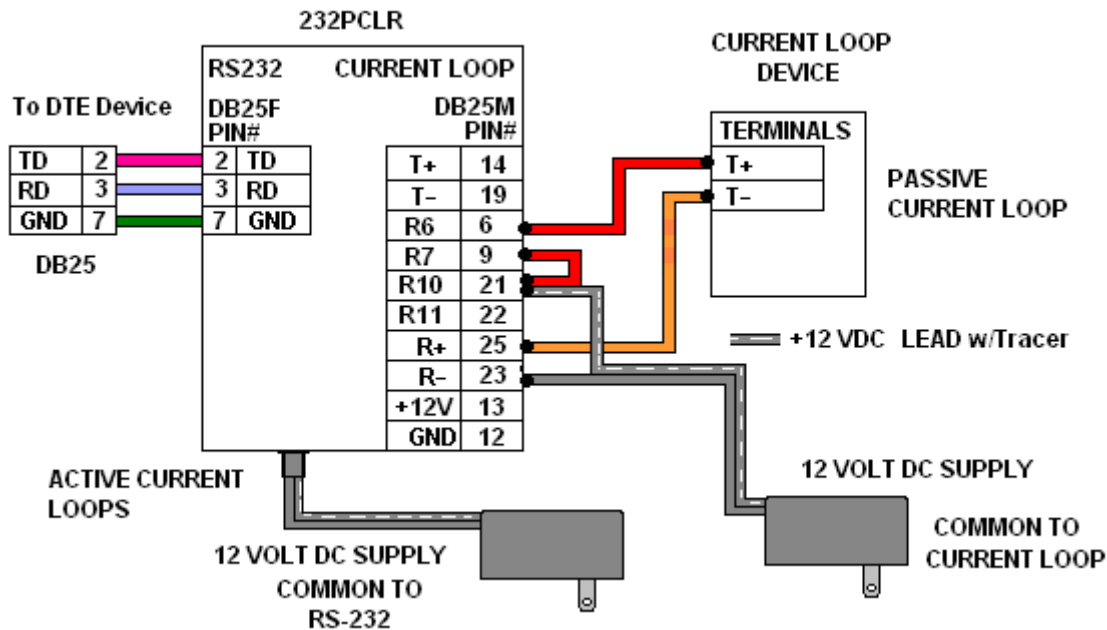

Fig. 8: Active Converter – Passive Device

To maintain isolation between the RS-232 device and the Current Loop device, a separate isolated power supply should be used to make the Current Loops active. If the Current Loop is made active using the same supply as the RS232 side of the converter, there will be no protective isolation.

When not sending or receiving data, each Current Loop should have around 20mA of current flowing. This can be measured for each loop by connecting a meter with a current scale in series with the Transmit or Receive line, observing meter polarity. In closed loop mode, the voltage drop across the Transmitter will be minimal, depending on the circuits, about 1.8V at the transmitter, around 1.8V at the Receiver.

DTE Device (Computer)				DTE	Connections	DCE	232CL4R 232CL9R 232PCLR		
DB9	DB25	RS-232 Signal Names			Signal Direction	DB9	DB25		
#1	#8	Carrier Detector (DCD)	CD			#1	#8	CD	
#2	#3	Receive Data (Rx)	RD	←		#2	#3	RD	
#3	#2	Transmit Data (Tx)	TD	→		#3	#2	TD	
#4	#20	Data Terminal Ready	DTR	→		#4	#20	DTR	
#5	#7	Signal Ground/Common (SG)	GND	→		#5	#7	GND	
#6	#6	Data Set Ready	DSR	→		#6	#6	DSR	
#7	#4	Request to Send	RTS	→		#7	#4	RTS	
#8	#5	Clear to Send	CTS	→		#8	#5	CTS	
#9	#22	Ring Indicator	RI	→		#9	#22		
Pin#	Soldered to DB9 Metal - Shield		FGND	→		Pin#			

RTS/CTS & DTR/DSR/CD loopbacks may be needed.

The RS-232 Connections depend on the type of Device the converter is connected to on the RS-232 side, if it is a DTE or DCE device. Computer devices are usually DTE, Data Terminal Equipment, Modem devices are DCE. Transmit is an output from a DTE, Receive is an output from a DCE. Devices wired the same must swap the connections for TD and RD.

Checking Pins to Determine: How to identify which of two lines is the output from the device:

Use a DC voltmeter, measure from the ground pin to Pin #2 or Pin#3. Usually one Pin from the source device has a minus (-) DC voltage, usually between -11 volts and -3 volts. Whichever lead has a minus voltage should be connected to the TD input pin, Pin #2 on the DB25, (Pin #9 on the 232CL9R) The other pin usually has no voltage or just noise relative to ground. If neither lead has a minus (or positive) voltage on it relative to ground, recheck for OPEN cable connections to the RS-232 device or the device pinouts. If the RS-232 device can be configured multiple ways, make sure all the jumpers and such are set to RS-232.

A few devices may use very low power RS-232 ports which switch only between Ground and positive voltage, so to identify which is line is active, the device must be set to transmit data, then tried. Some DC meters may show a slight flicker of DC or AC voltage on a RS-232 data line with changing data.

If the Current Loop Device is only sending data (such as a scale), and the Current Loop converter is only receiving, the Transmit data from the device only needs to connect to the Receive inputs on the Current Loop Converter, and Ground and Receive from the Converter to the computer or scale display.

This information should help you make the needed connections.